

INSTALLATION, USE AND MAINTENANCE MANUAL

MDDS DEHUMIDIFIER FOR OUTDOOR POOLS

MDCS PIPE DEHUMIDIFIER FOR SWIMMING POOLS
IN TECHNICAL ROOMS

MDOS HORIZONTAL DEHUMIDIFIER FOR SWIMMING POOLS,
MOUNTED UNDER A FALSE CEILING

Please read this manual before operating the machine
and keep it for future reference.

Dear Client,

Thank you for choosing our product. We are pleased to provide you with this manual to ensure that you get the most out of your product, as well as for your convenience and safety.

Please read the recommendations on the following pages carefully and make this manual available to personnel who will be responsible for operating and maintaining the device.

Our company is always ready to answer any questions you may have at the stage of commissioning the facility or at any other time.

Our Technical Department is always on hand to assist you and provide you with the spare parts you may need, especially during scheduled or unscheduled maintenance.

CONTENTS

I. Preface	5
1.1. Responsibility.....	6
1.2. Rules of operation	6
1.3. Use for the purpose	7
1.4. Areas of residual risk.....	8
1.5. Intervention and technical maintenance.....	9
1.6. General rules of technology safety	10
II. Product description	11
2.1. Components.....	11
2.2. Series.....	12
2.3. Boundary conditions operation	13
2.4. Sizes	13
2.5. Functions	13
2.6. Additional opportunities	14
2.7. Installation.....	16
2.8. Electrical circuits	17
III. Management system	18
3.1. Buttons	18
3.2. Main page	19
3.3. User menu.....	19
3.4. Menu of alarms signals	22
3.5. Device status menu	22
3.6. Menu of hourly ranges	23
3.7. Other pages	25
IV. Technical characteristics	26
4.1. Tables of technical characteristics: models MDDS, MDCS	26
4.2. Tables of technical characteristics: models MDOS	29
4.3. Performance characteristics.....	31
4.4. Functional scheme	33
V. After-sales service	34
5.1. Troubleshooting	34
5.2. Scheduled maintenance maintenance	35
5.3. Unscheduled technical maintenance	37
Vi. Dismantling device.....	39
6.1. Environmental protection environment	40
VII. Installation	41
7.1. Preface	41
7.2. Location	42
7.3. Hydraulic connections	45
7.4. Electrical connections.....	46
7.5. First startup, calibration and setup	50
VIII. Dimensional drawings	55
8.1. MDDS.....	55
8.2. MDCS	57
8.3. MDOS	61

I. PREFACE

This manual describes the intended use of the device and provides instructions for transporting, installing, assembling, adjusting, and operating it. The manual contains information on maintenance, ordering spare parts, residual risks, and training.

The following persons should read and use the User Manual:

- Each operator and all personnel involved in the operation and maintenance of the device must read this manual in its entirety and follow the instructions contained therein with the utmost care;
- The employer must ensure that the operator has the skills necessary to operate the device and has read the manual carefully; in addition, the employer must provide the operator with information about the risk of accidents, especially those caused by noise, the personal protective equipment provided and the general rules for accident prevention established by law or regulations in force internationally or in the country where the device is used;
- The manual must be available at all times to the user, supervisors and operators responsible for the transportation, installation, use, maintenance, repair and final dismantling of the device;
- Keep the manual away from sources of moisture and high temperatures and treat it as an integral part of the device throughout its lifetime, passing it on to other users or the next owner of the device;
- If there are updates, make sure that all of them are included in the text;
- Under no circumstances may any part of the manual be removed, torn out or rewritten; if the manual is lost or partially damaged and its contents can no longer be read in full, a new manual must be requested from the manufacturer: to do so, provide the manufacturer with the serial number of the device indicated on the rating plate.

Pay close attention when you see the following symbols. They are used to highlight special information, such as:

DANGER!

Dangerous situations that may occur while using the device - to ensure personal safety.

WARNING!

Dangerous situations that may occur when using the device - to prevent damage property and the device itself.

ATTENTION!

Additional information or recommendations on how to use the device correctly.

The manufacturer has the right to update the product and manuals and is not obligated to update previous versions, except in exceptional circumstances.

This manual reflects the available technologies at the time of sale of the device and may not be considered out of date when subsequent updates based on new technologies become available.

To request any updates to the User and Maintenance Guide and supplements to the User and Maintenance Guide, which are considered an integral part of the Guide, please use the contact information provided in this Guide.

For more information or to make any suggestions for improving this manual, please contact the manufacturer.

If the device is transferred to a third party, the manufacturer kindly requests that you provide the address of the new owner so that the manufacturer can forward any additions to the manual to the new user.

1.1. RESPONSIBILITY

The device is protected by a warranty in accordance with the contractual agreements concluded at the time of sale.

WARNING!

The manufacturer considers itself free from liability and any obligations, and the warranty form provided at the conclusion of the sale agreement, shall become void in the event of any accidents to persons or damage to property that may result therefrom:

- **Failure to follow the instructions in this manual regarding operation, use, maintenance, and events that are not related to the normal operation and proper use of the device;**
- making changes to the device or to the safety devices without the written permission of the manufacturer;
- unauthorized repair attempts;
- negligence in performing regular maintenance or use of non-original spare parts.

In any case, if the user claims that the accident was caused by a defect in the device, he or she must prove that the damage caused was the main and direct consequence of this "defect".

1.2. RULES OF OPERATION

The operating instructions described in this manual are an integral part of the delivery of the device. These rules are also intended for operators who have been trained in the use of this type of device and contain all the necessary and important information for safe operation and optimal use of the device.

Hasty and incomplete training leads to the operator improvising on the fly, which is the cause of many accidents.

WARNING!

Before you start, please read the following recommendations carefully and follow them strictly:

- **Initial startup must be performed exclusively by qualified personnel authorized by the manufacturer;**
- When installing or servicing the device, the rules in this manual must be followed in conjunction with the instructions on the device, and all necessary precautions must be taken in any case;
- These technical instructions, which are based on the Machinery Directive 2006/42/EC and its subsequent amendments, are intended to prevent possible accidents to persons and damage to property. In any case, always observe the national safety regulations;
- Do not remove or damage safety devices, markings and information labels - especially those required by law - and replace them if they become illegible.

The Machinery Directive 2006/42/EC sets out the following definitions:

DANGEROUS AREA: Any area within and/or near the machine in which the presence of a vulnerable person poses a risk to the health and safety of that person.

VULNERABLE PERSON: Any person who is wholly or partially in a hazardous area.

OPERATOR: The person or persons responsible for installing, operating, adjusting, maintaining, cleaning, repairing, and transporting the machine.

ATTENTION!

All operators must comply with accident prevention regulations (international or local). country for which the device is intended) to avoid possible accidents.

Please note that the European Union has issued certain Directives on health and safety at work, including Directives 89/391/EEC, 89/686/EEC, 89/654/EEC, 89/655/EEC, 89/656/EEC, 86/188/EEC, 92/58/EEC and 92/57/EEC, which every employer must comply with and monitor.

The devices have been designed and built in accordance with the current state of the art and technical regulations. All applicable laws, regulations, ordinances, decrees and directives for such machinery have been observed.

The materials and equipment used, as well as the production, quality assurance and control procedures, meet the highest standards of safety and reliability. The performance of the device, its trouble-free operation and durability are ensured by using the materials and parts mentioned above for the purpose specified in this user manual, by handling them with due care and by performing thorough maintenance and care in accordance with accepted standards.

1.3. USE FOR THE PURPOSE

The MDDS, MDCS, MDOS are dehumidifiers for small swimming pools installed outdoors, in a technical room or under a false ceiling and are intended for use in all environments where lack of humidity control can lead to structural damage.

These devices are intended for use in chlorine treated pools and are not intended for use in saltwater pools. They are recommended for use within the operating conditions specified in this manual.

DANGER!

The device can be installed in an environment where there is no danger of explosion, fire, and where there are vibrations or electromagnetic fields. In addition, it must not be operated in any way other than as specified or in a manner that disregards the required safety regulations.

WARNING!

The devices are designed for use in rooms with swimming pools or places with a high chlorine content and other corrosive substances. It is extremely important that the device is always switched on to avoid corrosive substances that may cause damage to the device.

- The device switched to "OFF" mode from the machine display will turn on again after 180 minutes in the "STANDBY" operating mode (no air treatment, ventilation at minimum speed).
- The unit is shipped from the factory set to dehumidify with the heating turned off to keep ventilation at a minimum.
- For scheduled and unscheduled maintenance, the device will necessarily be turned off and disconnected; it is good practice to perform maintenance, apply power to the device, and turn it back on as soon as possible.
- Do not stop the device for seasonal breaks.

WARNING!

All of these instructions are aimed at preventing the formation of chlorine deposits that can damage device.

WARNING!

The normal process of dehumidifying air inevitably leads to its heating. It is advisable to consider temperature of the pool environment.

1.4. AREAS OF RESIDUAL RISK

DANGER!

In some areas of the device, there are residual risks that could not be eliminated at the time of design or limited to safety guards due to the specific functionality of the device. Each operator must be aware of the residual risks present in this device in order to avoid accidents.

Areas of residual risks:

- risk of short circuit and fire caused by a short circuit;
- risk of explosion due to pressurized circuits and risk of contamination due to refrigerant in the circuit;
- risk of burns due to the presence of very hot pipes;
- risk of cuts.

1.5. INTERVENTION AND TECHNICAL MAINTENANCE

It is important to remember that the user manual is in no way a substitute for proper user experience. This manual is a reminder of the main activities that must be performed by operators who have received special training - for example, in a training course provided by the manufacturer - for certain maintenance operations.

Please read the following recommendations carefully:

- regular and accurate preventive maintenance always ensures a high level of operational safety of the device. If maintenance work is required on the device, do not delay it, have only qualified operators carry out the work and use only original spare parts;
- plan each task carefully;
- the operator's workstation must be clean and easy to access so that the necessary movements can be made without endangering themselves;
- operators should avoid clumsy actions and working in awkward conditions where they may lose their balance;
- operators should ensure that their clothing and/or hair is not caught or tangled in moving parts; a hat should be worn to secure long hair;
- wearing chains, bracelets, and wedding rings can also be dangerous;
- even wearing necklaces, bracelets and rings can be dangerous; the workplace must have proper lighting; insufficient or excessive lighting can be dangerous;
- before turning off the device before performing any maintenance, wait about 30 minutes to avoid burns;

DANGER!

- **Do not repair pipes under high pressure by welding;**
- **The presence of pressurized liquids in refrigerant circuits and the presence of electrical components can pose a hazard during installation and maintenance operations;**
- Try to keep the refrigerant circuit open for as little time as possible. When oil comes into contact with air, it absorbs large amounts of moisture, resulting in the formation of weak acids;
- Only qualified personnel are allowed to work with the device;
- Before performing any maintenance on the device, make sure it is disconnected from the power supply;
- make sure that the safety devices are working properly and that there is no doubt about their functioning; if not, do not start the device;
- Use only the tools provided by the manufacturer of the device. To avoid personal injury, do not use worn or damaged, low-quality, or homemade tools;

DANGER!

- **after cleaning the device, the operator must make sure that there are no worn, damaged or loose parts; if you find any such parts, have them repaired by a service technician;**
- Ensure that the area in which the device is used is always kept clean and tidy. Oil and grease stains, broken tools, or broken parts can cause injury to people by causing them to slip or trip over them and fall;
- Do not use flammable liquids to clean the device.

Do not use diesel fuel, gasoline, or solvents to clean the device, as they leave an oily film on the surface that promotes dust accumulation, and solvents (even weak ones) damage the paint and promote rusting. If water gets into electrical equipment, the contacts will oxidize, and this can lead to malfunctioning of the device. Therefore, do not use water or steam to clean sensors, connectors, or any other electrical parts.

Check the integrity of the pressure lines and other components that are subject to wear and tear. Also make sure that no liquid or harmful substances are leaking from the device. In the event of a leak, the operator must not restart the device until the problem is resolved.

1.6. GENERAL RULES OF TECHNOLOGY SAFETY

1.6.1. Fire extinguisher and first aid kit

Place a first aid kit and fire extinguisher near the device.

Periodically check that the fire extinguishers are filled and that all operators know how to use them. In the event of a fire, use the fire extinguisher in accordance with the relevant applicable regulations and call the fire brigade.

Periodically check the completeness of the first aid kit.

Make sure that emergency phone numbers are always available and recorded nearby.

ATTENTION!

The owner of the facility where the device is installed is responsible for providing fire extinguishers and a first aid kit.

1.6.2. Recommendations for reminders and maintenance

Place an information label on all sides of the device with the text: "MAINTENANCE IN PROGRESS".

Check the device carefully according to the checklist in this manual.



1.6.3. Signs with safety signs



General danger



Danger of electrical voltage



Risk of burns



Hazard: Moving mechanical parts



Risk of cuts and injuries

II. PRODUCT DESCRIPTION

The MDDS, MDCS and MDOS dehumidifiers are designed for use in small swimming pools with a high potential load that require round-the-clock operation. Although this product is typically installed in private swimming pools, the technical characteristics of the MDDS, MDCS and MDOS dehumidifiers allow them to be used in other environments such as underground facilities, museums, libraries, archives, places of worship, warehouses and generally places where the accumulation of condensation and moisture can lead to structural or product damage or simply cause discomfort.

The MDDS, MDCS, MDOS dehumidifiers combine state-of-the-art technical solutions with elegant yet minimalist aesthetics, so they can be easily installed in prestigious locations characterized by sophisticated design. Thanks to the highest quality components specially designed for use in refrigeration, hydraulic, pneumatic and electrical equipment, the MDDS, MDCS and MDOS dehumidifiers are at the forefront of technology in terms of efficiency, reliability and sound power output. The MDDS, MDCS, MDOS dryers are designed in such a way that they can be easily inspected and scheduled and unscheduled maintenance can be performed quickly and easily.

Thanks to a large number of auxiliary equipment, these devices can be easily adapted to any order, and if the standard range and available auxiliary equipment are not enough to meet the customer's needs, the Company is ready to develop special solutions.

The MDDS, MDCS and MDOS dehumidifier range consists of 36 models with a capacity of 350 to 2000 m³/h and 46 to 290 liters of moisture per day and is a market benchmark due to the large number of available sizes, the wide range of air flow rates and dehumidification capacities, and the attractive design.

2.1. COMPONENTS

2.1.1. Construction

The device has an exclusive design that, together with the enclosed design of the machine, ensures that all components are inaccessible to external influences. The removable front panel, which provides access to all components of the device, ensures easy and quick maintenance.

Screws and fastening systems are made of non-oxidizing materials, stainless steel or carbon steel grades, and their surface is treated with passivation. The condensate collection tank is made of stainless steel. Wooden structures are fully painted with polyester paint, which provides protection against corrosion. The heat exchangers are made with an anti-corrosion paint surface coating.

2.1.2. Refrigerant circuits

The refrigerant circuit is entirely manufactured by the Company using only the highest quality components. Production processes are carried out by specialized personnel only. The assembly, welding, and wiring of each device is carried out entirely in-house, which guarantees high product reliability. The product range complies with Directive 97/23/EC. All machines are filled with environmentally friendly R410a gas.

Components of the refrigerant circuit:

- Compressors: rotary or scroll type, from leading international brands. The motors are protected from overheating by internal protection that monitors the temperature of the windings and switches off the power supply if necessary.
- Dewatering filter with molecular sieve.
- Layered element or thermostatic valve, depending on the model size.
- Liquid level indicator.
- High pressure switch.
- Nipples for adjusting operating pressures and/or for maintenance of the refrigerant circuit.
- The heat exchanger batteries are painted for resistance to the corrosive atmosphere of swimming pools.

2.1.3. Ventilation

The standard version of the MDDS and MDCS models (except for sizes 210 - 230 - 300) uses centrifugal fans with adjustable speed and double suction, with a plastic impeller and fan for greater resistance to corrosion and to significantly reduce noise emissions into the environment, and thus for maximum acoustic comfort.

The MDOS models and, on request, the MDDS and MDCS models use single-suction electronic centrifugal fans with plastic impeller and fan for greater resistance to corrosion and to significantly reduce noise emitted into the environment, thus providing greater acoustic comfort.

2.2. SERIES

There are 36 models to choose from, categorized by model and dehumidification rate. The numerical value represents the dehumidification capacity in liters per day.

Series	Dehumidification capacity, l/day										
	40	50	60	70	90	100	160	190	210	230	300
MDDS	40	50	60	70	90	100	160	190	210	230	300
MDCS	40	50	60	70	90	100	160	190	210	230	300
MDOS	–	–	–	70	90	100	160	190	210	230	–

2.3. BOUNDARY CONDITIONS OPERATION

Outside of the limit conditions specified below, the operation of the device is not guaranteed.

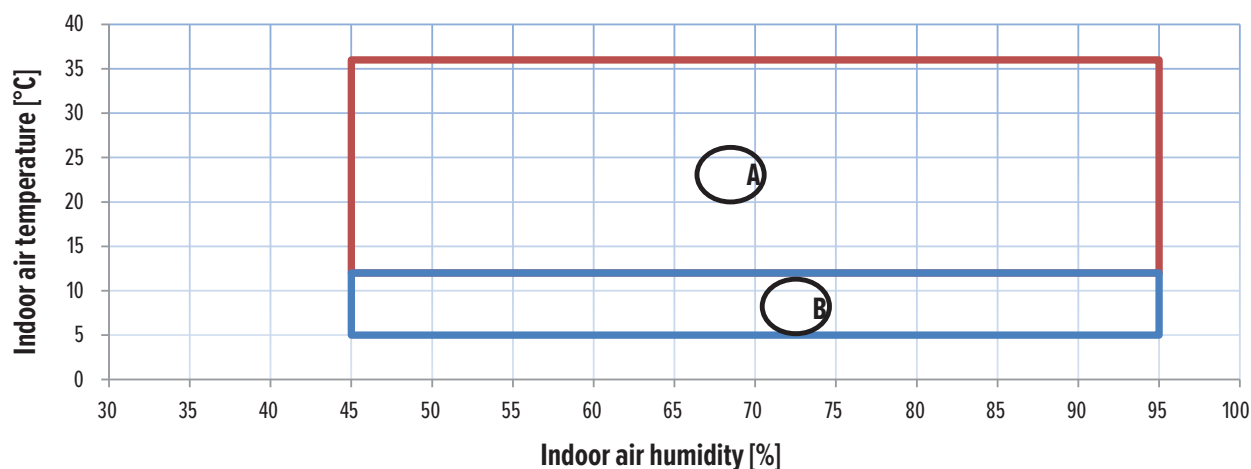

- A. Limit conditions of the dehumidifier
- B. Additional boundary conditions for operation with a hot gas defrosting unit supplied on a separate order

2.4. SIZES

Series	40	50	60	70	90	100	160	190	210	230	300
MDDS	850×780×280 mm			1050×780×280 mm			1350×850×330 mm		1550×850×330 mm		
MDCS	802×763×257 mm			1002×763×257 mm			1302×833×307 mm		1502×833×307 mm		
MDOS	–			1105×800×410 mm			1105×1051×510 mm			–	

2.5. FUNCTIONS

The MDDS, MDCS, MDOS devices are equipped with a powerful control system with a graphic display and built-in temperature and humidity sensors, thanks to which the dehumidifier reads and controls temperature and humidity indicators completely autonomously.

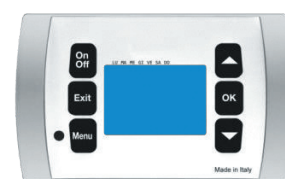

The control system consists of a board equipped with a programmable microprocessor and a graphic display, which allows for a large number of functions and options that can be easily controlled through a simple, comprehensive and intuitive interface.

The control software for the humidifier was developed entirely in-house by highly qualified technicians. The control display can be used remotely - up to 20 meters away - and, thanks to the temperature and humidity sensors installed on the machine, it can be used to control the temperature, humidity, and standby time ranges of the machine.

Customized software of a special version is available on request.

All control functions are listed below:

- Displays the operating status of the device and/or alarms.
- Temperature and humidity sensors on the machine.
- Low vapor pressure protection sensor.
- Controls 3 ventilation speeds for dehumidification, recirculation and heating.
- Manage timeout ranges.
- Temperature control by time intervals.
- Humidity control by time intervals.
- Manage the history of alarms.
- Simultaneous control of the electric heating elements and the hot water heat exchanger via a 3-way valve (except for models 040 - 050 - 060).
- Automatic control of static frost defrosting.
- Automatic control of frost defrosting with hot gas.
- Digital output for the general alarm signal.
- Graphic display with backlight.
- Possibility to use the display remotely to place it on the wall.

2.6. ADDITIONAL OPPORTUNITIES

Model	MDDS	MDCS	MDOS
Hot water coil equipped with 3-way valve	•	•	•
Electric heating elements	•	•	•
Modulated electronically commutated (EC) fan	•	•	SERIES
Defrosting frost with hot gas	•	•	•
Quiet design with soundproofed compressor	•	•	•
Kit for remote use of the display (10 or 20 m)	•	•	–
RS485 Modbus serial interface board	•	•	•
Set of support legs for floor installation	•	–	–
Set of boxes for crossing the wall (2 pcs.)	–	•	–
Supply and return air ducts (2 pcs.)	–	•	–
Supply and return air grilles (2 pcs.)	–	•	–
Display mounted on the device	–	–	–
Rectangular flange kit for top air outlet	–	–	–
Rectangular flange kit for rear air outlet	–	–	–
Cables for remote communication (5, 10 or 20 m)	–	–	•
Remote display with connection cable (2 m)	–	–	SERIES
Highly efficient filter	–	–	•
Inlet flange set for circular ducts	–	–	•
Return flange set for circular channels	–	–	•

- additional option available
- additional feature is not available

2.6.1. Hot water heat exchanger with 3-way valve

This system consists of a heat exchanger for heating the air after drying with hot water and a 3-way valve directly controlled by the unit and is designed to heat the supply air with hot water from a boiler or heat pump. The unit is delivered with the heat exchanger and valve already assembled and electrically connected.

The location of the water pipe connections is shown in the dimensional drawings.

2.6.2. Electric heating elements

These elements allow the supply air to be heated in the absence of hot water. To ensure safety, a thermostat is provided that switches off the heating elements and sounds an alarm in the event of overheating. The unit is delivered with the electric heating elements already installed inside.

2.6.3. Modulated electronically commutated (EC) fan

The fans mounted inside the device are modulated electronically commutated brushless fans.

2.6.4. Defrosting frost with hot gas

This system consists of a gas valve through which hot gas is injected into the evaporative heat exchanger, ensuring rapid frost defrosting and expanding the dehumidifier's application range.

2.6.5. Quiet design with soundproofed compressor

Reduces compressor noise: The dehumidifier is particularly quiet. This system consists of a sound absorbing mat in the compressor compartment that absorbs the noise generated by the compressor.

2.6.6. Kit for remote use of the display (10 or 20 m)

Use to move the device display to a more convenient location.

The kit consists of a ready-to-connect cable with a length of 10 or 20 m and a cover to cover the display hole in the device.

2.6.7. RS485 Modbus serial interface board

Allows you to connect the RS485 Modbus interface for remote monitoring or control via a home automation system. More information is available upon request.

2.6.8. Set of support legs for floor installation

These feet, available only for the MDDS version, allow the unit to be installed on the floor without having to mount it on the wall. They are required whenever the wall cannot support the weight of the unit.

2.6.9. Set of boxes for crossing the wall (2 pcs.)

This accessory is only available with the MDCS version. It allows the unit to be mounted on a wall adjacent to the room to be dehumidified. During assembly, the ducts must be cut to the desired size (they are suitable for walls up to 300 mm thick) and inserted into the wall.

2.6.10. Supply and return air ducts (2 pcs.)

This accessory can only be supplied with the MDCS version. It allows the unit to be mounted on a wall adjacent to the room where the air is to be dehumidified. The boxes should be attached to the unit with the air flow facing the wall.

2.6.11. Supply and return air grilles (2 pcs.)

This accessory can only be supplied with the MDCS version. It allows the unit to be mounted on a wall adjacent to the room to be dehumidified. The grilles must be installed in the wall penetration ducts leading out of the room to be dehumidified. These fixed fin grilles are made of anodized aluminum and have a pleasingly elegant yet minimalist design.

2.6.12. Cables for remote communication (5, 10 or 20 m)

A shielded 2-conductor cable is provided in 5, 10, or 20 m lengths, ready and adjusted for connection between the machine and the wall display. This option is only available for MDOS devices.

2.6.13. Remote display with connection cable (2 m)

The display is supplied with the device, and a 2-meter shielded, ready-to-connect cable between the machine and the wall display is available for MDOS devices only.

2.6.14. Highly efficient filter

A more efficient filter is installed than the one already present in the device: it makes the air cleaner and more efficiently captures dust particles that enter the device from the outside.

2.6.15. Inlet flange set for circular ducts

The flange allows the supply air to be connected to the unit via spiral hoses. For sizes 70, 90 and 100, a flange with a 250 mm diameter hole is mounted, and for sizes 160, 190, 210 and 230, a flange with two 250 mm diameter holes is mounted. This option is only available for MDOS devices.

2.6.16. Return flange set for circular channels

The flange allows the return air to be discharged from the unit via spiral hoses. For sizes 70, 90 and 100, a flange with a 250 mm diameter hole is mounted, and for sizes 160, 190, 210 and 230, a flange with two 250 mm diameter holes is mounted. This option is only available for MDOS devices.

2.7. INSTALLATION

MDDS and MDOS are designed to be installed directly in the room where the air is to be dehumidified.

MDCS units are designed to be installed in a technical room adjacent to the room to be dehumidified and are supplied without a front cover (see dimensional drawings).

MDCS units are designed to be connected to ducts, supply and return air ducts and ventilation grilles (optional) or other types of ductwork that allow air to be removed from the room and delivered to the room where the air is to be dehumidified.

2.8. ELECTRICAL CIRCUITS

The design and wiring connections of the electrical panel are made in accordance with EN 60204-1.

All remote controls are implemented using low-voltage signals, which are powered by an isolation transformer.

WARNING!

Do not disconnect the device by de-energizing the protective equipment installed in front of the device; this equipment should be used to disconnect the entire device before servicing. To temporarily turn off the device, use the user remote control.

III. MANAGEMENT SYSTEM

The control system consists of a power supply board and an elegant display that is used to control the device and make changes to various functions.

The functions of the various buttons and all existing display pages are described below.

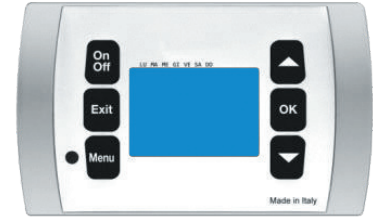

3.1. BUTTONS



ON/OFF KEY

Pressing this key on the Home page temporarily turns off the device.

- Pressing this key on the OFF and STANDBY pages turns the device on.



EXIT BUTTON

■ Use to exit and return to the Home page.

■ If you change a value, it lets you exit the change process.

■ If you press this key on the main screen for 4 seconds, the software version is displayed.



MENU KEY

■ Pressing this key on the Home page takes you to the first page of the User Menu.

■ Press this key on the time slot programming pages to change the day of the program.



UP KEY

■ Use to scroll through screens or change a value.



OK KEY

■ Use to perform the action shown on the display.



"DOWN" KEY

■ Use to scroll through screens or change a value.

3.2. MAIN PAGE

⚠ ATTENTION!

USE OF KEYS:

- Pressing the OFF key turns the device off.
- Pressing and holding the EXIT key temporarily displays the software version.
- Pressing the MENU key opens the user menu.



- — this symbol is located at the top and shows the current day.
- 15:55 — shows the current time.
- 20°C — shows the current temperature.
- 75% — shows the current humidity.
- 2 — indicates that the fan is on and running at the second speed.
- ☉ — indicates that the device is dehumidifying the air.
- ☀ — indicates that the heating device is active.
- 🕒 — indicates the presence of active time intervals.
- 📡 — indicates that the device is controlled via the Modbus protocol.
- ❄️ — shows that frost thawing is active.
- CLEAN THE AIR FILTERS** — reminds you to check that the air filters are clean. To hide the notification, simply press the EXIT key.

3.3. USER MENU

The user menu consists of 9 very simple pages for basic configuration of the device:

1. Control the device: manually or by time intervals. *
2. Setting the desired humidity. *
3. Setting the desired temperature. *
4. Alarm management. *
5. Programming time ranges.
6. Language settings.
7. Setting the day and time.
8. Displays the status of the device.
9. Password request.

* The page does not always exist. Each page has a page number on the right to facilitate its use.

⚠ ATTENTION!

USE OF KEYS:

- Press the UP and DOWN keys to move from one page to the next (some screens are not always displayed).
- Press the EXIT key to exit and return to the home page.
- Click the OK button to perform the function specified on the page.

Let's take a closer look at the different pages of the user menu:

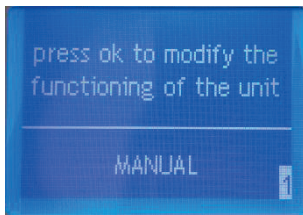

Page 1 of the user menu, shown on the left, is used to configure the control of the device: "MANUAL" or by setting "TIME INTERVALS". *(This page is not displayed if the device is controlled via the Modbus serial interface).*

- Press the OK key to enter the setting change stage; press the UP and DOWN keys to change the value, and press the OK key to confirm the selection and exit the setting change stage.
- Press the EXIT key to exit and return to the home page.
- Press the DOWN key to go to the next page.

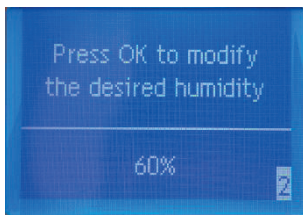

Page 2 of the user menu, shown on the left, is used to set the desired humidity. *(This page is not displayed if the device is controlled via the Modbus serial interface or if this setting is set in time intervals.)*

- Press the OK key to enter the setting change stage; press the UP and DOWN keys to change the value, and press the OK key to confirm the selection and exit the setting change stage.
- Press the EXIT key to exit and return to the home page.
- Press the UP key to return to the previous page.
- Press the DOWN key to go to the next page.



Page 3 of the user menu, shown on the left, is used to set the desired temperature. *(This page is not displayed if the device is controlled via the Modbus serial interface, if this setting is set in time intervals, or if there are no heating options.)*

- Press the OK key to enter the setting change stage; press the UP and DOWN keys to change the value, and press the OK key to confirm the selection and exit the setting change stage.
- Press the EXIT key to exit and return to the home page.
- Press the UP key to return to the previous page.
- Press the DOWN key to go to the next page.



Page 4 of the user menu, shown on the left, is used to manage the alarms that are present. *(This page is displayed if there are alarms.)*

- Press the OK key to enter the alarms menu.
- Press the EXIT key to exit and return to the home page.
- Press the UP key to return to the previous page.
- Press the DOWN key to go to the next page.

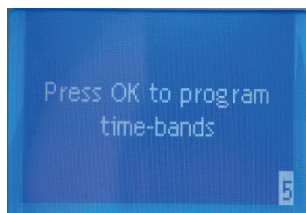

Page 5 of the user menu, shown on the left, is used to program time intervals. *(This page is not displayed if the device is controlled via the Modbus serial interface or if manual control is set.)*

- Press the OK key to enter the time ranges menu.
- Press the EXIT key to exit and return to the home page.
- Press the UP key to return to the previous page.
- Press the DOWN key to go to the next page.

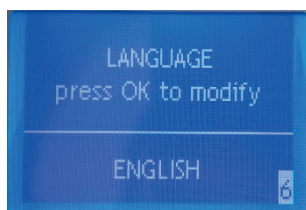

Page 6 of the user menu, shown on the left, is used to set the language.

- Press the OK key to enter the setting change stage; press the UP and DOWN keys to change the value, and press the OK key to confirm the selection and exit the setting change stage.
- Press the EXIT key to exit and return to the home page.
- Press the UP key to return to the previous page.
- Press the DOWN key to go to the next page.

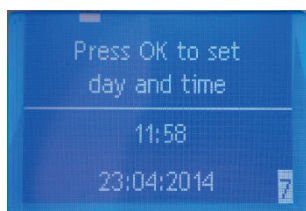

Page 7 of the user menu, shown on the left, is used to set the time and date, which are necessary for the correct functioning of time slots and other device functions.

This is where you consistently change such data:

1. day of the week;
 2. an hour;
 3. minutes;
 4. day;
 5. month;
 6. year.
- Press the OK key to enter the setting change stage, and press the UP and DOWN keys to change the setting.
 - Press OK to confirm your selection and move on to changing the next value.
 - After changing the last value, click OK to confirm the changes and exit the settings stage.
 - Press the EXIT key to exit and return to the home page.
 - Press the UP key to return to the previous page.
 - Press the DOWN key to go to the next page.

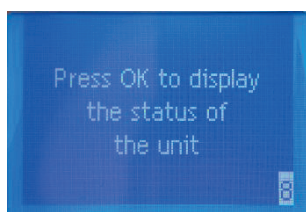

Page 8 of the user menu, shown on the left, is used to view the status of the device (i.e., whether it is on or off) and the temperature and humidity sensor readings.

- Press OK to enter the device status menu.
- Press the EXIT key to exit and return to the home page.
- Press the UP key to return to the previous page.
- Press the DOWN key to go to the next page.



Page 9 of the user menu, shown on the left, is used to change password-protected settings.

- Clicking OK will take you to the password request page.
- Press the EXIT key to exit and return to the home page.
- Press the UP key to return to the previous page.

3.4. MENU OF ALARMS SIGNALS

This menu is only available when the device has alarms. You can display the active alarm and, if possible, reset it.



On the left is a page where you can choose whether to display the alarm or reset it.

- Press the EXIT key to exit and return to the home page.
- Press the UP and DOWN keys to select what you want to do.
- Press OK to confirm your selection and go to the page below.



On the left is an example of a page that displays an alarm. At the bottom, the component that the alarm is related to or the type of alarm is displayed; in this example, the alarm occurred in the heating electrical pages. This page is of great help in case of alarms.

- Press the EXIT button to exit and return to the previous page.



The page for resetting alarms is shown on the left. Only some alarms can be reset. When resetting alarms, remember that resetting does not eliminate the cause of the alarm, and the alarm may occur again.

- If you press and hold the OK button for 3 seconds, the alarm clears and you are returned to the main page.
- Press the EXIT key to exit and return to the alarm menu.

3.5. DEVICE STATUS MENU

This menu is always available and shows all information on the status of the device, including the following lines: fan, compressor, water valve, electric heater, ambient temperature, ambient humidity, evaporation temperature, frost defrost temperature, water temperature, dehumidification command, heating command.

The water valve and electric heater are optional equipment that may not be present in the unit, in which case several dashes will be displayed in the corresponding line.

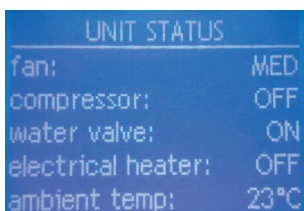

On the left is the device status page. In this case, you can see that the fan is running at medium speed, the compressor is off, the water valve is present and open, the heating electric resistor is present and off, and the ambient temperature is 23°C.

- Press the UP and DOWN keys to scroll through the page and display other rows.
- Press the EXIT key to exit and return to the home page.

3.6. MENU OF HOURLY RANGES

This menu is available only if the device is set to operate in time intervals and uses interval programming that controls the wait, humidity, and temperature.

⚠ ATTENTION!

It is extremely important to set the current time and date - to do this, go to page 7 of the user menu (for more information, see the previous paragraphs).

The following values are set by default:

- the device is always on (24 hours/day and 7 days/week);
- the desired humidity is always 60% (24 hours/day and 7 days/week);
- the desired temperature is set for each day:
 - 28°C from 08:00 to 20:00
 - 25°C from 20:00 to 8:00

You can set different parameters for each hour of the day and for each day of the week.

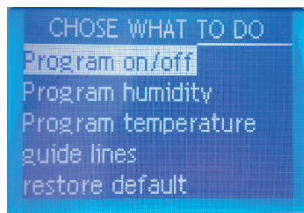

On the left is a page where you can choose what you want to do.

- Press the EXIT key to exit and return to the home page.
- Press the UP and DOWN keys to select what you want to do.
- Click OK to confirm your selection and go to the page below.

The temperature program only exists if an optional hot water coil with valve or heating electric resistor is purchased.

3.6.1. Program on - humidity program - temperature program

When you select a program, the programming page opens; the humidity programming is shown below.

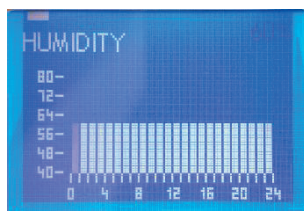

- After entering the page, the first bar corresponding to the period from 00:00 to 01:00 will start blinking, and the value set in the upper right part of the page will start blinking.
- In the upper left part of the page, you can see a rectangle representing the day you are programming.
- Under the day rectangle, the program topic is indicated: "HUMIDITY".
- There is a bar at the bottom of the page that displays 24 hours.
- On the left is a bar that shows the desired humidity that you can set.

ATTENTION!

USE OF KEYS:

- Press the OK key to change the time for which you are programming.
- Press the MENU key to change the day for which you are programming.
- Press the UP and DOWN keys to change the programmed value for the flashing hour.
- Use the EXIT key to return to the previous page.
- Pressing OK and MENU at the same time will copy the program for the active day to the next day.

3.6.2. Guide

If you select this guide, you will be presented with 5 screens that explain how to set up the program for time slots.

ATTENTION!

USE OF KEYS:

- Use the UP and DOWN keys to move between these 5 pages.
- Use the EXIT key to return to the previous page.

3.6.3. Restore the default settings

When you first program the time intervals, you may make a mistake, or you may have set the time intervals in a certain way, but after a while it turned out that this programming is not ideal. In both cases, you can completely cancel the programming and start from the default values.

If you select the Restore Defaults option, a page opens where you can restore all the values of the time intervals.

ATTENTION!

USE OF KEYS:

- Hold down the OK key for 3 seconds to restore all values.
- Use the EXIT key to return to the previous page.

3.7. OTHER PAGES

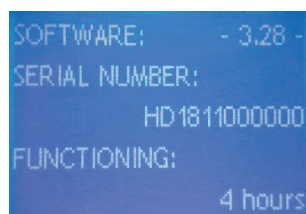

3.7.1. Shutdown and standby page

Use this page to turn on the device by pressing the ON-OFF button.

If the device remains switched off for more than 180 minutes, the standby mode is automatically activated: this is indicated by the corresponding inscription on this page. In standby mode, the ventilation is switched on at the minimum speed.

3.7.2. Software version

This page is used to view the software version downloaded during advanced adjustment and the serial number of the device; this page can only be accessed from the Home page by holding down the EXIT button for 3 seconds. This page is displayed for a few seconds, after which the unit automatically returns to the main page.

3.7.3. Password

On this page, enter the password to change advanced settings.

- Press the EXIT key to exit and return to the home page.
- Press the UP and DOWN keys to set each digit of the password.
- Click OK to change the next digit or to confirm the password.

IV. TECHNICAL CHARACTERISTICS

4.1. TABLES OF TECHNICAL CHARACTERISTICS: MODELS MDDS, MDCS

Model	Units	040	050	060	070
Dehumidification performance	l/day	46	52	62	68
Nominal air flow rate	m ³ /h	350	450	500	600
Useful static head	Pa	40	40	40	40
Sound pressure	dB(A)	43	45	46	47
The power of the hot water coil	kW	3,7	4,5	4,8	6,1
Pressure loss in a water coil with a valve	kPa	11	16	17	35
Electrical power supply	H / F / Hz	230 / 1 + neutral / 50			
Power of the heating element	kW	1	1	1,5	2
Rated compressor capacity	kW	0,7	0,7	0,9	0,85
Rated current of the compressor	A	3,34	3,34	3,89	3,89
Rated power of the device	kW	0,8	0,8	0,9	0,9
Maximum power of the device	kW	1,1	1,1	1,3	1,3
Rated current of the device	A	3,5	3,6	4,2	4,2
Maximum current of the device	A	5,1	5,1	5,7	5,8
Peak current of the device	A	19,1	19,1	19,1	19,2
Maximum current of the device with resistors	A	9,5	9,5	12,2	14,5
Peak current of the device with resistors	A	23,4	23,4	25,6	27,9
Dimensions of the MDDS model (W x D x H)	mm	850×280×780	850×280×780	850×280×780	1050×280×780
Dimensions of the MDCS model (W x D x H)	mm	803×257×764	803×257×764	803×257×764	1003×256 ×745
Weight	kg	46	46	46	55
Refrigerant	type	R410A	R410A	R410A	R410A

The dehumidification capacity is stated for a nominal point at 30°C / 80% RH. The currents and power consumption are stated for a rated point at 30°C / 80% RH. Hot water coil power is stated at an ambient temperature of 30°C and water temperatures of 80°C inlet and 70°C outlet. Sound was measured at a distance of 1 meter, in free space. Under different conditions, the declared values may change, and these changes may also be more important the more the conditions deviate from the nominal operating conditions.

Model	Units	090	100	160	190
Dehumidification performance	l/day	89	98	165	186
Nominal air flow rate	m ³ /h	700	800	1000	1200
Useful static head	Pa	40	40	40	40
Sound pressure	dB(A)	48	49	51	53
The power of the hot water coil	kW	6,8	7,5	10,1	11,5
Pressure loss in a water coil with a valve	kPa	42	50	24	31
Electrical power supply	H / F / Hz	230 / 1+ neutral / 50			
Power of the heating element	kW	3,2	3,2	4	4
Rated compressor capacity	kW	1,37	1,37	2	2,49
Rated current of the compressor	A	6,37	6,37	9,1	11,5
Rated power of the device	kW	1,5	1,5	2,2	2,7
Maximum power of the device	kW	2	2	3	3,3
Rated current of the device	A	6,8	6,8	9,9	12,4
Maximum current of the device	A	8,9	8,9	13,7	15,1
Peak current of the device	A	36,5	36,5	55	63
Maximum current of the device with resistors	A	22,8	22,8	31,1	32,5
Peak current of the device with resistors	A	50,4	50,4	72,4	80,4
Dimensions of the MDDS model (W x D x H)	mm	1050×280×780	1050×280×780	1350×330×850	1350×330×850
Dimensions of the MDCS model (W x D x H)	mm	1003×256×745	1003×256×745	1302×306×834	1302×306×834
Weight	kg	55	55	88	88
Refrigerant	type	R410A	R410A	R410A	R410A

The dehumidification capacity is stated for a nominal point at 30°C / 80% RH. The currents and power consumption are stated for a rated point at 30°C / 80% RH. Hot water coil power is stated at an ambient temperature of 30°C and water temperatures of 80°C inlet and 70°C outlet. Sound was measured at a distance of 1 meter, in free space. Under different conditions, the declared values may change, and these changes may also be more important the more the conditions deviate from the nominal operating conditions.

Model	Units	210	230	300
Dehumidification performance	l/day	211	226	290
Nominal air flow rate	m ³ /h	1500	1500	2000
Useful static head	Pa	40	40	40
Sound pressure	dB(A)	54	55	57
The power of the hot water coil	kW	14,5	14,5	17
Pressure loss in a water coil with a valve	kPa	52	52	67
Electrical power supply	H / F / Hz	400 / 3 + neutral / 50		
Power of the heating element	kW	7,2	7,2	7,2
Rated compressor capacity	kW	3,15	3,24	4,12
Rated current of the compressor	A	5,9	6,1	7,4
Rated power of the device	kW	3,4	3,5	4,4
Maximum power of the device	kW	4,9	5	6,2
Rated current of the device	A	7,1	7,3	8,9
Maximum current of the device	A	9,5	9,6	11,2
Peak current of the device	A	50	50	65
Maximum current of the device with resistors	A	23,4	23,5	25,1
Peak current of the device with resistors	A	63,9	63,9	78,9
Dimensions of the MDDS model (W x D x H)	mm	1550×330×850	1550×330×850	1550×330×850
Dimensions of the MDCS model (W x D x H)	mm	1503×306×834	1503×306×834	1503×306×834
Weight	kg	100	100	102
Refrigerant	type	R410A	R410A	R410A

The dehumidification capacity is stated for a nominal point at 30°C / 80% RH. The currents and power consumption are stated for a rated point at 30°C / 80% RH. Hot water coil power is stated at an ambient temperature of 30°C and water temperatures of 80°C inlet and 70°C outlet. Sound was measured at a distance of 1 meter, in free space. Under different conditions, the declared values may change, and these changes may also be more important the more the conditions deviate from the nominal operating conditions.

4.2. TABLES OF TECHNICAL CHARACTERISTICS: MODELS MDOS

Model	Units	070	090	100	160
Dehumidification performance	l/day	67	92	99	161
Nominal air flow rate	m ³ /h	600	700	800	1000
Useful static head	Pa	200	175	150	230
Sound pressure	dB(A)	46	47	48	50
The power of the hot water coil	kW	6,1	6,8	7,5	10,4
Pressure loss in a water coil with a valve	kPa	33	40	47	34
Electrical power supply	H / F / Hz	230 / 1 + neutral / 50			
Power of the heating element	kW	2	3	3	4
Rated compressor capacity	kW	0,85	1,37	1,37	2
Rated current of the compressor	A	3,89	6,37	6,37	9,1
Rated power of the device	kW	0,93	1,47	1,65	2,19
Maximum power of the device	kW	1,36	2,02	2,18	3,27
Rated current of the device	A	4,6	7,1	8,6	10,6
Maximum current of the device	A	6,6	9,7	11	16,3
Peak current of the device	A	20	37,3	38,6	57,6
Maximum current of the device with resistors	A	15,3	22,8	24,1	33,7
Peak current of the device with resistors	A	28,7	50,3	51,6	75
Dimensions (W x D x H)	mm	1105×800×410	1105×800×410	1105×800×410	1105×1050×510
Weight	kg	84	84	84	147
Refrigerant	type	R410A	R410A	R410A	R410A

The dehumidification capacity is stated for a nominal point at 30°C / 80% RH. The currents and power consumption are stated for a rated point at 30°C / 80% RH. Hot water coil power is stated at an ambient temperature of 30°C and water temperatures of 80°C inlet and 70°C outlet. Sound was measured at a distance of 1 meter, in free space. Under different conditions, the declared values may change, and these changes may also be more important the more the conditions deviate from the nominal operating conditions.

Model	Units	190	210	230
Dehumidification performance	l/day	182	213	225
Nominal air flow rate	m ³ /h	1200	1500	1500
Useful static head	Pa	200	150	150
Sound pressure	dB(A)	52	53	54
The power of the hot water coil	kW	11,9	13,3	13,3
Pressure loss in a water coil with a valve	kPa	44	55	55
Electrical power supply	H / F / Hz	230 / 1 + neutral / 50	400 / 3 + neutral / 50	
Power of the heating element	kW	4	4	4
Rated compressor capacity	kW	2,49	3,15	3,24
Rated current of the compressor	A	11,5	5,9	6,1
Rated power of the device	kW	2,74	3,48	3,57
Maximum power of the device	kW	3,53	4,97	5,03
Rated current of the device	A	13,5	8,4	8,6
Maximum current of the device	A	17,7	11,1	11,2
Peak current of the device	A	65,6	51,6	51,6
Maximum current of the device with resistors	A	35,1	19,8	19,9
Peak current of the device with resistors	A	83	60,3	60,3
Dimensions (W x D x H)	mm	1105×1050×510	1105×1050×510	1105×1050×510
Weight	kg	147	168	168
Refrigerant	type	R410A	R410A	R410A

The dehumidification capacity is stated for a nominal point at 30°C / 80% RH. The currents and power consumption are stated for a rated point at 30°C / 80% RH. Hot water coil power is stated at an ambient temperature of 30°C and water temperatures of 80°C inlet and 70°C outlet. Sound was measured at a distance of 1 meter, in free space. Under different conditions, the declared values may change, and these changes may also be more important the more the conditions deviate from the nominal operating conditions.

4.3. PERFORMANCE CHARACTERISTICS

The temperature is displayed on the bottom axis.

The dehumidification capacity is displayed on the left axis.

To calculate the dehumidification capacity at a specific operating point:

- On the bottom axis, find the point that corresponds to the ambient temperature.
- From this point, draw a perpendicular upward to the intersection with the ambient humidity curve.
- From the intersection point, draw a perpendicular to the left and read the dehumidification capacity at this operating point.

40

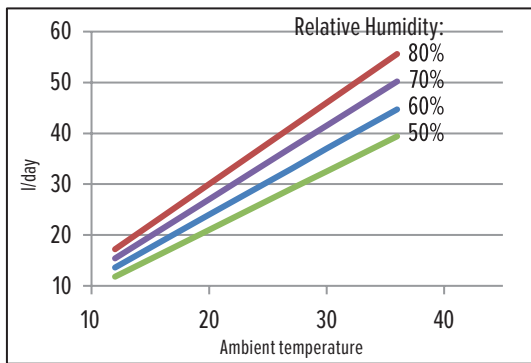

50

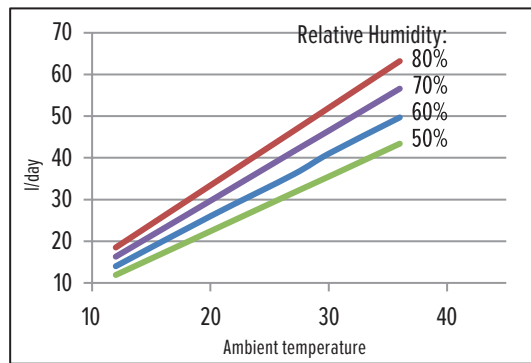

60

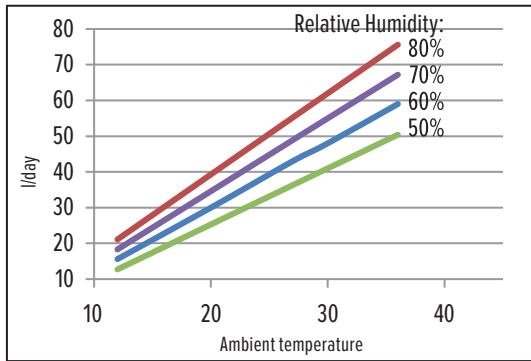

70

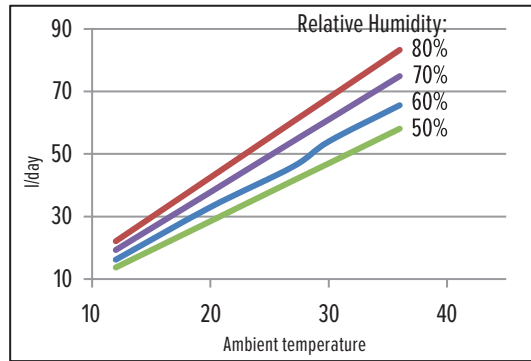

90

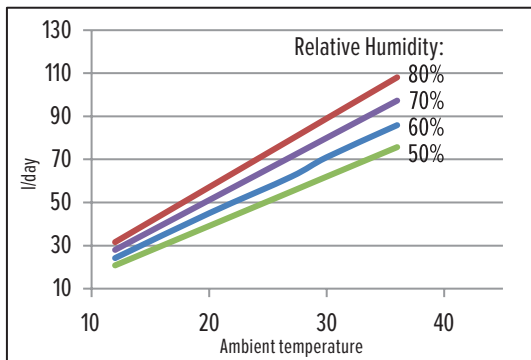

100

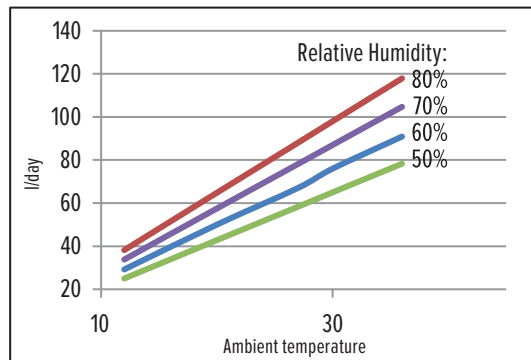

160

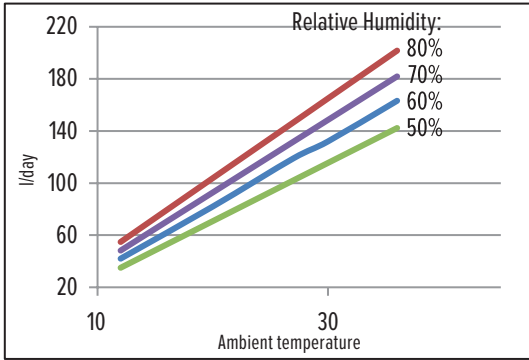

190

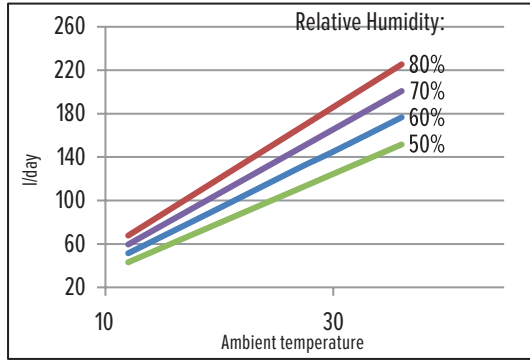

210

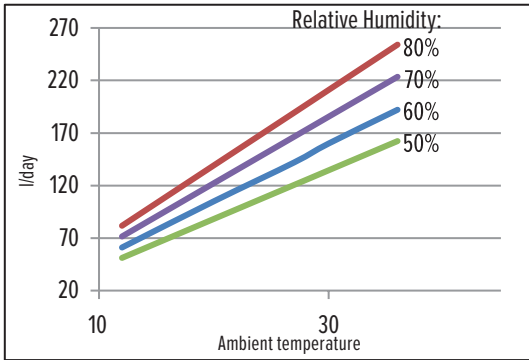

230

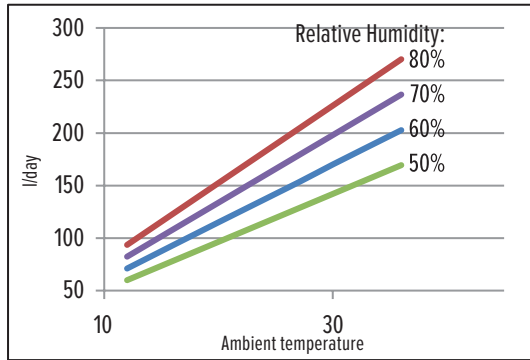

300

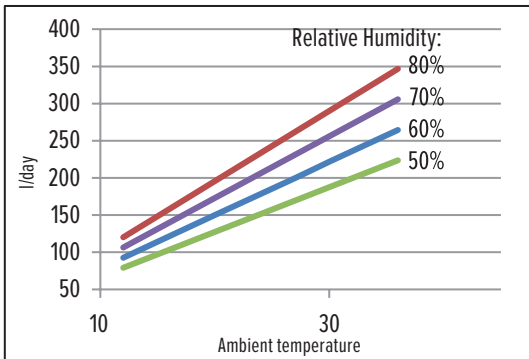

4.4. FUNCTIONAL SCHEME

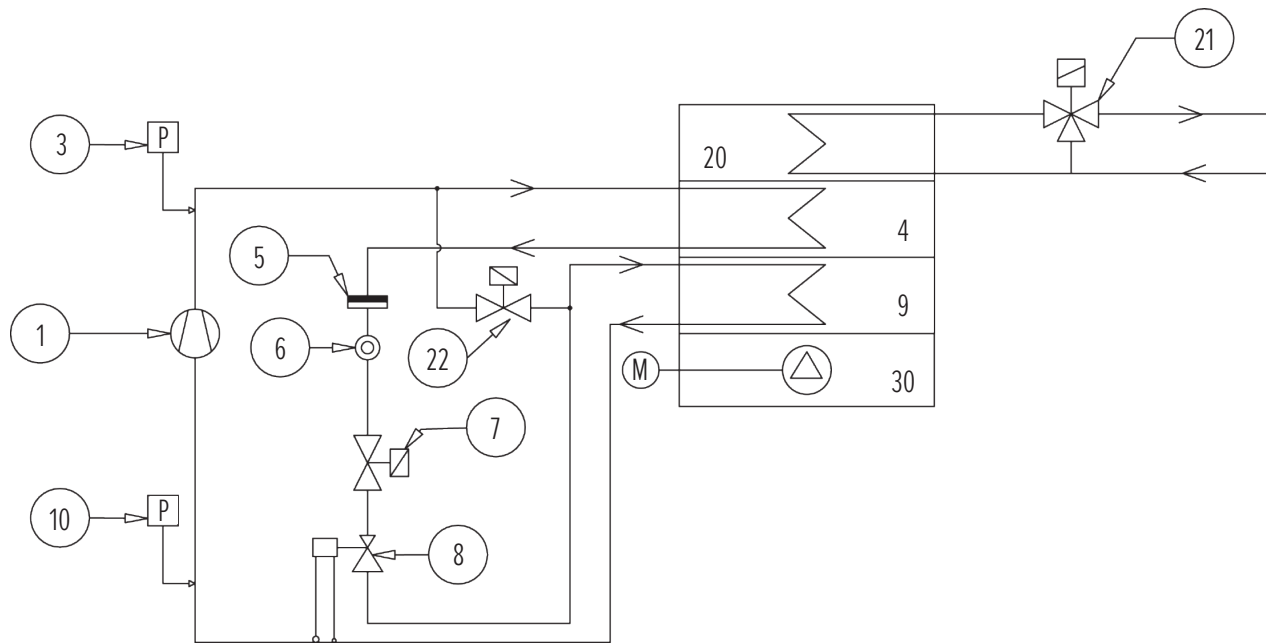

1. compressor
2. high pressure switch
3. condensing heat exchanger
4. dewatering filter
5. flow indicator
6. solenoid valve
7. layered elements
8. evaporative heat exchanger
9. low pressure sensor
10. water heat exchanger for heating the air after drying
11. 3-way water valve
12. valve for defrosting frost with hot gas

V. AFTER-SALES SERVICE

5.1. TROUBLESHOOTING

The following pages list the most common causes of clogging or at least malfunctioning of the appliance. They are grouped by symptoms that are easy to identify.

DANGER!

Be very careful when performing the suggested operations to solve various problems: significant inattention can lead to serious injury. Once the cause of the malfunction has been identified, we recommend that you contact the manufacturer or a qualified technician.

N°	Failure	Analysis of possible causes	Troubleshooting actions
1	The device does not start	There is no electrical power to the device	Check for voltage at the power supply terminals
		No power supply to the electronic board	Check for voltage at the board terminals
		There are alarms present	Check for terminal alarms, eliminate their causes, and restart the device
		Power cut due to phase sequence relay tripping (models 210, 230, and 300 only)	Check the correct phase sequence (see paragraph "Electrical connections on the panel")
2	The compressor does not start	The internal overheating protection element has been triggered	Unplug the device, wait for it to cool down, and then plug it back in to see if it restarts Determine the cause of the security alert and resolve it
		High pressure protection in the refrigerant circuit is activated	See violation 3
		The set humidity setpoint does not allow the compressor to start	Set a different humidity setpoint
		Low ambient temperature	Heat the room to a temperature of more than 12°C or, only if the optional hot gas frost defrosting system is installed, more than 5°C
3	High pressure	Improper air flow rate	Check the filters, heat exchangers, and refrigerant recovery unit for cleanliness
			Make sure that all fans are rotating correctly.
			Check the length and number of channel bends and, if the device is not equipped with electronic fans, reduce the length and number of these bends, and if such fans are installed, increase the fan speed (see paragraph "Flow rate calibration for devices with an electronic fan")
		Other reasons	Call a specialized technician

N°	Failure	Analysis of possible causes	Troubleshooting actions
4	Low pressure	Ice has formed on the evaporative heat exchanger	If there is ice on the evaporative coil, temporarily turn off the unit and melt any ice.
		Other reasons	Call a specialized technician
5	Overheating of the electric heating element	Improper air flow rate	Check the filters, heat exchanger, and refrigerant recovery unit for cleanliness
			Make sure that all fans are rotating correctly.
		Check the length and number of channel bends and, if the device is not equipped with electronic fans, reduce the length and number of these bends, and if such fans are installed, increase the fan speed (see paragraph "Flow rate calibration for devices with an electronic fan")	
	Other reasons	Call a specialized technician	
6	Alarm signal for ejection from the machine	Loss of refrigerant gas	Call a specialized technician

5.2. SCHEDULED MAINTENANCE MAINTENANCE

5.2.1. Cleaning/replacing the air filters

WARNING!

There is no standard frequency at which the filters should be cleaned. Air filters are clogged depends on the use of the device and the area in which it is installed. Check the filters periodically for cleanliness. We remind you that if the air filters are not cleaned properly or removed from the device, there are serious risks that could jeopardize the proper functioning and serviceability of the device. Failure to clean/replace the filters will void the warranty.

Clean the filters with a vacuum cleaner and manually remove any dirt that may be obstructing the proper airflow, taking care not to damage the filters. If any of the filters are broken, punctured, or otherwise damaged, they must be replaced.

WARNING!

When removing the operating panels, the filters may fall out. Therefore, when opening the device, be very Make sure that the air filters do not fall to the ground.

To clear the "Clean air filters" message from the display, press the EXIT button.

MDDS – MDCS

Tilt the filter down.



Pull out the filter and remove it.



MDOS

For routine maintenance, simply remove the bottom panel as shown in the illustration: to do so, simply unscrew the screws and the filter will fall out with the panel.

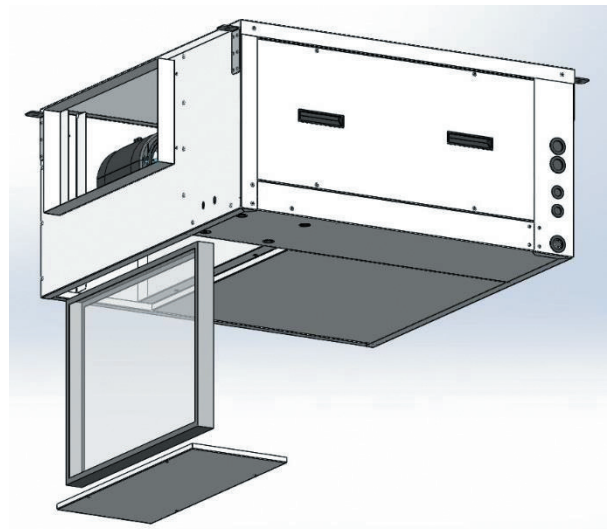

5.3. UNSCHEDULED TECHNICAL MAINTENANCE

5.3.1. Cleaning the condensate tray and condensate drain pipe

MDDS-MDCS

1. Loosen the screws on the top completely, lift the cover, and remove it (MDDS model only).
2. Loosen the screws and remove the right corner panel covering the compartment containing the electrical panel and compressor.
3. Loosen the screws and remove the left-hand panel covering the compartment containing the heat exchanger, fan and tank.
4. Clean the drip tray with a damp cloth and check that the drip tray is not blocked.
5. Reassemble all the parts by reversing this procedure.

MDOS

1. Loosen the screws holding the filter panel in place and remove it together with the filter cover panel: the filter itself will fall out as well.
2. Loosen the screws on the side operating panel leading to the compressor compartment and remove the panel.
3. Reach the screws holding the bottom panel of the unit in place from the compressor compartment and the back of the unit and remove them to gain access to the tank.
4. Remove the bottom panel by pushing it toward the product outlet.
5. Disconnect the condensate drain hose from the drip tray.
6. Loosen the screws that hold the tank in place. First, loosen the screws that hold the tank to the control panel leading to the resistors, and then remove the screws that hold it in place from the inside and outside of the unit.
7. Remove the tray.
8. Clean the drip tray with a damp cloth and check that the drip tray is not clogged.
9. Reassemble all the parts by reversing this procedure.

5.3.2. Maintenance table

To ensure that the performance of the device remains consistent over time, we recommend that you refer to this table when performing and planning any maintenance on the device.

YEAR	IV quarter	III quarter	II quarter	I quarter	IV quarter	III quarter	II quarter	I quarter	IV quarter	III quarter	II quarter	I quarter	IV quarter	III quarter	II quarter	I quarter
	IV quarter	III quarter	II quarter	I quarter	IV quarter	III quarter	II quarter	I quarter	IV quarter	III quarter	II quarter	I quarter	IV quarter	III quarter	II quarter	I quarter
MAINTENANCE																
Operation of control and safety equipment																
Condition, mounting and balancing of fans																
Condition and mounting of compressors																
Normal noise level generated by the device																
No oil leaks from the compressor																
No refrigerant leaks from the refrigerant circuit																
No water leaks from the hydraulic circuit																
Checking the terminals on the electrical panel																
Cleaning/replacing the air filters																
Cleaning/replacing the condensate drip tray																
Cleaning the heat exchanger																

VI. DISMANTLING DEVICE

When a device reaches the end of its service life and needs to be dismantled and replaced, a number of steps must be taken:

- The refrigerant must be collected by qualified personnel and sent to a special collection center.
- The compressor oil must be collected and sent to a special collection center.



If the structure and various components of a device cannot be reused, they must be disassembled and separated by material type. This is especially true for copper and aluminum, which are present in significant quantities in the device.

This will facilitate the work performed at waste collection, recycling and recovery facilities and minimize the environmental impact of such processes.

WARNING!

If the device or a part of it is to be decommissioned, the components must be disposed of, that may be dangerous.

When replacing any part, if the used part must be disposed of separately, always comply with the relevant applicable laws and regulations.

Please note that the loading and unloading of special and toxic waste must be recorded.

Special and toxic waste must be collected by authorized companies.

Special and toxic wastes must be disposed of in accordance with the applicable laws and regulations in the country of use. The device must be dismantled in accordance with the applicable laws and regulations in the country of use. Before disassembling the device, contact the appropriate authorized body for an inspection and issuance of a certificate. Finally, have the device recycled in accordance with the applicable laws in the user's country.

ATTENTION!

Have qualified personnel dismantle and disassemble the device.

6.1. ENVIRONMENTAL PROTECTION ENVIRONMENT

The law (Regulation EC 2037/00) governing the use of substances that deplete the stratospheric ozone layer and greenhouse gases prohibits the release of gaseous refrigerants into the environment and requires that at the end of their useful life, owners collect them and return them to the seller or give them to a proper waste collection facility.

R410A refrigerant does not harm the ozone layer, but it is a greenhouse gas and is therefore subject to the above regulations.

WARNING!

Therefore, during maintenance operations, it is recommended to pay special attention to minimize refrigerant leaks.

VII. INSTALLATION

7.1. PREFACE

7.1.1. Overview

Upon receipt of the device, check it for any damage: the device is shipped from the factory in perfect condition. If you find any signs of damage, please report it immediately to the carrier and indicate these defects on the "Consignment Note" before signing it.

The manufacturer or its representative must be notified as soon as possible of the extent of the damage. The customer must provide a written report describing all significant signs of damage.

7.1.2. Lifting and transportation

When unloading the device and reinstalling it, take great care to avoid rough handling. Use extreme caution when moving the device indoors. Do not lift the device by its components.

WARNING!

During all shipping operations, ensure that the device is properly secured so that it has not been dropped or tipped over. Do not move or lift the device by the removable panels.

7.1.3. Unpacking

The packaging of the device should be removed carefully to avoid damaging the device. The packaging consists of various packaging materials: wood, cardboard, nylon, etc. They should be sorted and taken to the appropriate waste disposal or recycling facilities to minimize their impact on the environment.

7.1.4. Device identification

Each unit is characterized by a nameplate that contains all the data required for installation, maintenance and traceability. On the MDDS-MDCS models, the nameplate is located above the display, and on the MDOS model, it is located on the outside of the compressor compartment.

Make a note of the model, serial number, the exact amount of refrigerant charged, and the reference drawings of the unit on the nameplate on the side of the unit so that this information can be easily accessed when the nameplate is worn out.

Modello	
Matricola - Serial number	
Data di produzione	
Categoria PED / CE 97/23 - Category of pressure equipment / Category according to CE Directive 97/23	
Procedura di valutazione conformità	
Max temp. di stoccaggio - Maximum storage temperature [°C].	
Max temp. max temp. funzionamento - Maximum operating ambient temperature [°C]	
Min. temp. ambiente di funzionamento - Minimum operating ambient temperature [°C].	
Potenza frigorifera nominale - Rated cooling capacity [kW].	
Potenza frigorifera nominale - Rated cooling capacity [kW].	
Refrigerant - Refrigerant [Ashrae standard 15/1992].	
Carica refrigerante - Amount of refrigerant charged in the system [kg].	
Peso a vuoto - Own weight [kg]	
Alimentazione - Electrical power supply	
Potenza assorbita Nominale - Nominal input power [kW].	
Corrente nominale - Rated current consumption [A].	
Corrente massima - Full load current (FLA) [A].	
Corrente di spunto - Starting current (current when the compressor rotor is braked - LRA) [A].	
Schema elettrico - Wiring diagram	
Schema frigorifero - Refrigerant circuit diagram	

7.2. LOCATION

WARNING!

All MDDS, MDCS, and MDOS models are designed and built for indoor installation. Do not install the device outdoors and make sure that it is not exposed to the elements such as rain, hail, humidity, and frost.

When choosing the optimal location for the device and the location of the corresponding connections, pay attention to the following points:

- The dimensions of the hydraulic pipes and the place from which they are supplied (if any);
- location of the power supply source;
- accessibility for use, maintenance, and repair;
- stability of the surface to which the device is attached;
- Do not mount the device at high altitudes to avoid blocking due to high temperatures.

It is crucial to ensure full access to the device. It is recommended to cushion each attachment point or support point with vibration isolation material to prevent noise and vibration from spreading.

7.2.1. Education around the MDDS model

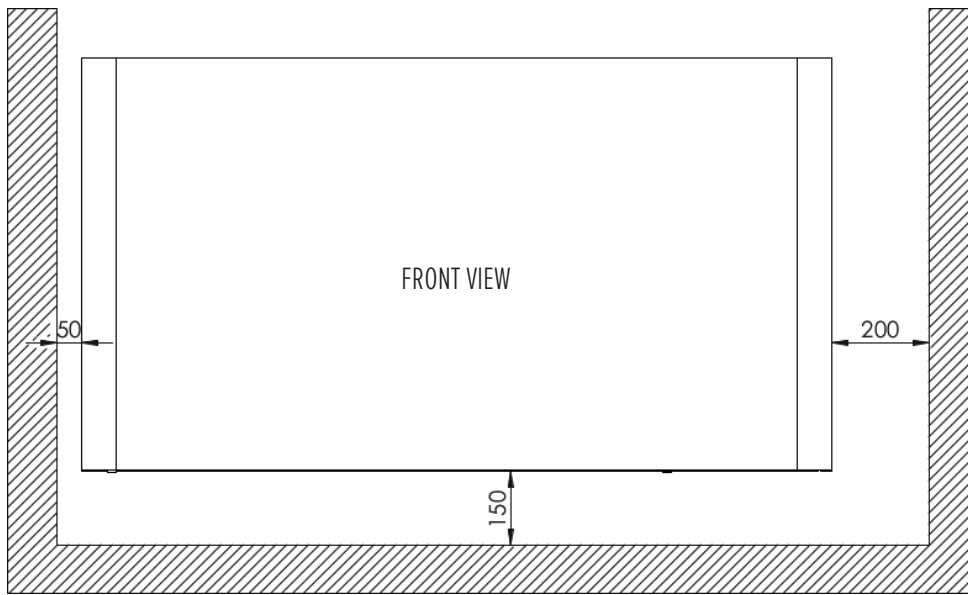

7.2.2. Education around the MDCS model

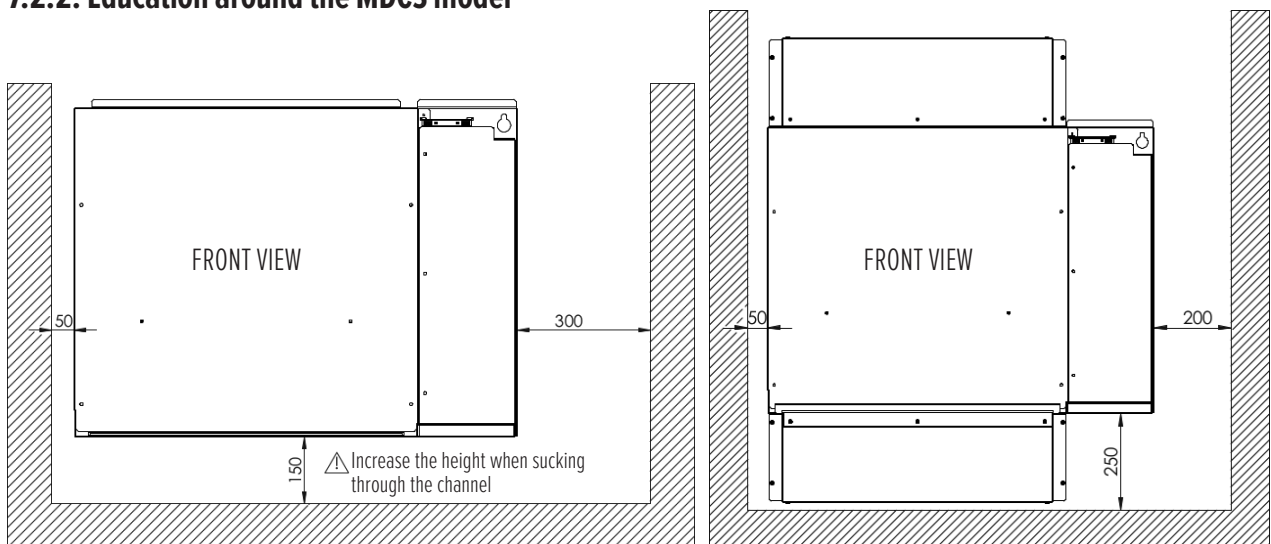

7.2.3. Enlightenment around the MDOS model

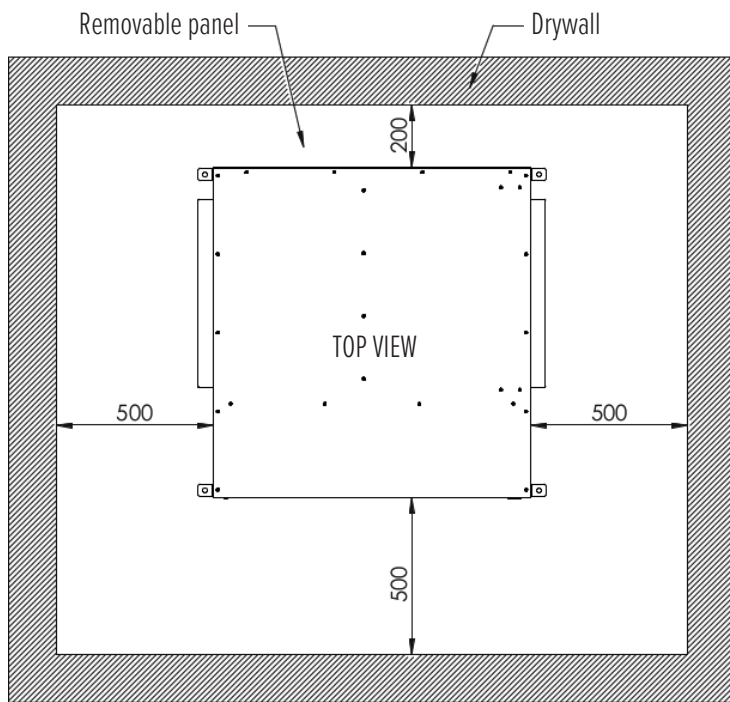
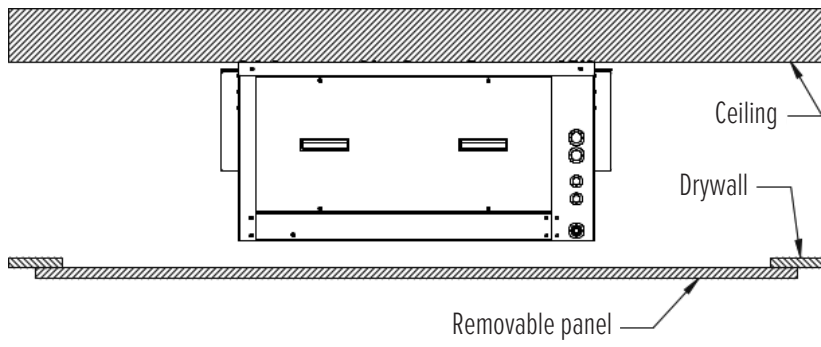

7.3. HYDRAULIC CONNECTIONS

The following requirements must be observed when installing the hydraulic circuit and national or local regulations must be observed in all cases.

WARNING!

Do not twist the connecting parts of the device. Hold the connecting part stationary with the the key, secure the adapter with another key.

Use flexible joints for pipe connections to ensure vibration damping and thermal expansion compensation. The following components should be installed on the pipelines:

- temperature and pressure indicators for routine maintenance and inspection of the device. Pressure monitoring allows you to assess the correct functioning of the expansion tank and detect water leaks in advance;
- shut-off valves (flaps) to shut off the hydraulic circuit in case of tampering with it during maintenance;
- a mechanical filter (on the inlet pipe) equipped with a 1 mm mesh to protect the heat exchanger from contaminants present in the pipes. This requirement must be fulfilled during commissioning in the first place;
- Purge valves, which are installed at the highest points in the hydraulic circuit so that the circuit can be purged with air;
- a drain valve and drain tank, if required, to empty the system before maintenance;
- If the device is used in process lines, it is recommended to install a separate heat exchanger to prevent clogging of the device's heat exchangers.

ATTENTION!

It is extremely important that the water inlet is arranged through the connection labeled "Inlet water", otherwise the countercurrent pattern will not be observed and there is a risk of malfunction, clogging or damage to the device.

The dimensions and location of the hydraulic connections are shown in the dimensional drawings.

WARNING!

The hydraulic circuit must be designed in such a way as to guarantee a constant rated water consumption (+/- 15%) under all operating conditions.

7.3.1 Making a condensate drain connection

The connection should be made with a flexible rubber hose with an inner diameter of 16 mm. There is no siphon inside the device. It is not necessary to install a siphon.

⚠ WARNING!

The slope of the drainage pipe should be such that water flows out of the device in any case outside. If this condition is not met and water accumulates in the drip tray inside the unit, the tray may overflow, causing water to leak from the unit.

7.4. ELECTRICAL CONNECTIONS

Open the electrical panel, lead the power cable and other necessary cables inside through the holes provided for them, make the connections on the clamps, and close the panel.

⚠ DANGER!

It is imperative to provide a grounding lead. The installer must connect the wire grounding to a specially provided clamp located inside the electrical panel and marked with markings.

⚠ DANGER!

When making wiring connections, the device must be disconnected from the power supply. **MORTAL DANGER!**

Electrical connections, power cables, and protective equipment must be arranged in accordance with the enclosed wiring diagram and in compliance with local and international regulations.

7.4.1. Рекомендуемый выключатель MGT, который нужно установить на линии перед устройством

Models	MDDS MDCS										
	Single-phase								Three-phase		
	40	50	60	70	90	100	160	190	210	230	300
Without electric heating element	C10	C10	C10	C10	C16	C16	C20	C20	C16	C16	C16
With electric heating element	C16	C16	C20	C20	C32	C32	C40	C40	C32	C32	C32

Models	MDOS						
	Single-phase					Three-phase	
	70	90	100	160	190	210	230
Without electric heating element	C10	C16	C16	C20	C20	C16	C16
With electric heating element	C20	C32	C32	C40	C40	C32	C32

7.4.2. Equipment location Models MDDS and MDCS

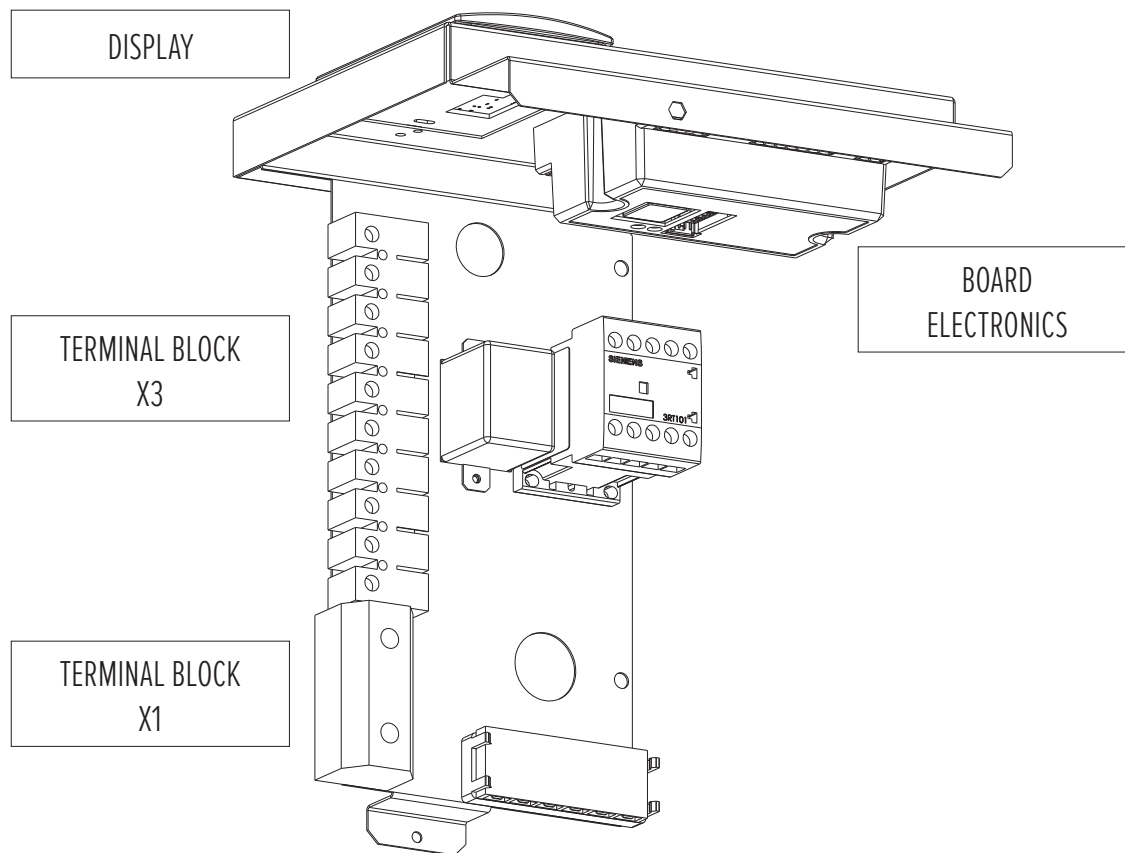

7.4.3. Electrical connections on the panel

Terminal plate X1

This terminal block is used to provide electrical power to the device.

- For models 40-50-60-70-90-11-160-190, connect the phase, neutral, and protective earth.
- For models 210-230-300, connect 3 phases, neutral, and protective earth.

⚠ ATTENTION!

Check that the phase sequence is correct (models 210 - 230 - 300 only). Make sure that the phases are connected in the correct sequence. The correct phase sequence can be checked using a special relay mounted on the electrical panel. The phase sequence relay has two indicator LEDs. If the green LED is on, all three phases are present. If it is not lit, check if a line of one of the three phases is broken. If the yellow LED is on, the phases are alternating in the correct order. If it is not lit, check the correct phase sequence.



Terminal plate X3

Terminals 101 - 102 are used for the device alarm; you can connect an indicator lamp or a system control unit to them. To turn on the contact, follow the procedure described in paragraph 7.4.1.

In MDDS/MDCS models, the command is delivered as a 230 V voltage (not available with the optional hot gas frost defrosting system).

For MDOS models, connect only the dry contact.

Terminals 103 – 104 are used to connect the transducer tip to a water valve or water pump area (max. 1 A) to control the water supply to the device. For devices with a current consumption of more than 1 A, install a power relay.

The drive operates at 230 V.

Terminals 105 – 106 are used for remote control: connect a switch or control unit contact to these terminals to remotely control the device's power on.

Connect only dry contacts.

- contact is open → device is off
- contact closed → device switched on

Terminals 107 – 108 are used for switching dehumidification on/off, for connecting a switch contact or a control unit to control the remote dehumidification switching on.

Connect only dry contacts.

- contact open → dehumidification command is inactive
- contact closed → dehumidification command active

Terminals 109 – 110 are used for switching the heating on/off: connect a switch or control unit contact to these terminals to remotely control the heating switch on.

This contact only works when an optional hot water exchanger with valve or heating electric resistor has been purchased.

Connect only dry contacts.

- contact open → heating command is inactive
- contact closed → heating command active

ATTENTION!

In addition to connecting the wiring, you must configure the terminal for the first startup on/off contacts (remote control - dehumidification - heating); the logic of each contact can be reversed if necessary. See the relevant paragraph.

EXAMPLES:

- **If the user wants the device to be switched on with a wall switch,** to use the remote contact, connect 2 wires of the switch to terminals 105 - 106 and switch the contact to remote operation during the first startup.
- **Operating the control unit for a temperature control system with a dry contact for dehumidification and a dry contact for heating:** To use the dehumidification on/off contact and the heating on/off contact, connect the control unit's dehumidification on/off contact to terminals 107 to 108 and the control unit's heating on/off contact to terminals 109 to 110, and turn on the dehumidification and heating contacts during initial startup.

7.4.4. Connecting the display

MDDS and MDCS devices are shipped with the display attached to the device and electrically connected. In the case of MDOS devices, the display is shipped disconnected. The installer must mount the display on the wall and connect it to the device.

If you are installing the MDDS or MDCS in an inaccessible location, you can purchase a remote display kit that includes a 5, 10, or 20-meter cable, ready to connect, and a cover plate to cover the display opening.

In this case, the installer needs to remove the display from the unit, mount the display on the wall, and use the cable provided in this kit to connect the display to the unit and cover the remaining opening in the unit with the included unit opening cover panel.



The display should be installed in a convenient position so that the user can perform basic operations, display the operating status of the device, and display alarms if they occur.

- Plan the location of the 503 box so that it is horizontal in the wall.
- Remove the bottom screw in the display housing.
- Feed the cable through the holes provided at the back and secure the base to the wall-mounted box.
- Close the control panel again.

To connect the display, connect the cable coming from the device as shown below:

- (negative pole) first core and screen + (positive pole) second core

Use CEAM cable Y08761 or equivalent.

If the poles are reversed, the display will not work. The poles are indicated both on the black plastic power supply board (on the device) and on the back of the display.

Кабель следует подключить так, как показано ниже:



7.4.5. Connecting the RS485 to Modbus interface (optional)

Connect the Modbus RS485 cable to the detachable terminal marked in the figure at right. On all connected devices, ensure that the phases A and B are connected correctly and connect the shielded cable to the ground (GND) terminal.

To configure the Modbus interface, see the installer's guide on the following pages.

The RS485 Modbus interface does not have to be connected, but the device always has a terminal for it. Make sure that you have configured this capability, otherwise the device will not work. To connect the entire Modbus system/network, use the CEAM cable Y08761 or similar.



7.5. FIRST STARTUP, CALIBRATION AND SETUP

WARNING!

The first launch and setup should be performed by specialized personnel only.

Before starting up, make sure that all panels are in place and tightly secured with screws. Follow the following instructions to put the device into operation:

DANGER!

Ensure that all hydraulic, electrical and pneumatic connections are correctly mounted, and All instructions on the labeling and in the user manual have been followed.

Make sure that all valves in the refrigerant circuit, if any, are open and that the hydraulic system is free of air: to do this, remove any remaining air from the circuit by gradually filling it and opening the air vents on top.

Make sure there are no water leaks.

The device is shipped from the factory ready for use; to perform the first startup, follow the steps below:

1. Turn on the power to the device.
2. Make sure the device is OFF; if it is not, press the ON/OFF button to turn it off.
3. **Leave the device OFF for 2 hours before turning it on for the first time.**
4. After this time has elapsed, press the ON/OFF button to turn the device on.

7.5.1. Flow calibration in a device with an electronic fan

WARNING!

The recirculation fan only needs to be calibrated if the air flow is discharged to the environment through the duct, the rated flow rate is reduced and the fan speed must be increased to compensate for the pressure loss. A duct anemometer (duct thermoanemometer) is required to calibrate the unit.

If the measured flow rate is 10% higher or lower than the nominal flow rate listed in the technical data table, the rotation speed must be changed using the built-in user terminal. This function is necessary to ensure correct operation of the device.

For different devices, you need to ensure the following nominal flow rates:

	Models	40	50	60	70	90	100	160	190	210	230	300
Nominal flow rates in m ³ /h	MDDS MDCS	350	450	500	600	700	800	1000	1200	1500	1500	2000
	MDOS	–	–	–	600	700	800	1000	1200	1500	1500	–

After setting the display, go to the Home screen by pressing the EXIT key (repeatedly if necessary) or pressing the ON/OFF key if the unit is off.

ATTENTION!

At the stage of changing parameters (highlighted parameters), the program will wait for confirmation without leaving from the page.

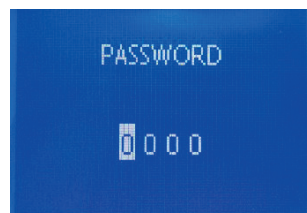

Press the UP, DOWN, and OK keys on the right simultaneously. The screen shown on the left is displayed. On this screen, the system prompts you for your password. Enter 0099 and press the OK key to confirm.



Press OK to start the calibration.

You are now in the calibration menu shown in the figure on the left. On the right, you can increase the speed of the recirculation fan for all those installations in which the air flow is through the ductwork and therefore the pressure loss increases.

Next, measure the flow rate with an anemometer and make sure that the flow rate has reached the rated value. If not, increase the value until you reach the rated flow rate.

Default: 0%.

Once the rated flow rate is reached, press the EXIT button repeatedly to return to the main screen.

7.5.2. Configuration of installer parameters

You can change some advanced device settings using the installer options.

⚠ WARNING!

Some settings significantly change the operation of the device. CHANGE THEM ONLY IF NECESSARY.

To enter the editor menu, do the following:

- return to the main page by pressing the EXIT button, if necessary;
- press the MENU key to go to the first page of the user menu;
- press the DOWN key to scroll through the pages until you reach the last page (page 9);
- press the OK button;
- the system will ask you for a password: enter the password "0010" and press OK to confirm.

⚠ ATTENTION!

USE OF KEYS:

- Press the UP and DOWN keys to move from one screen to the next (some screens are not always displayed).
- Press the EXIT key to exit the menu and return to the Home screen.
- By pressing the OK button, you will perform the function indicated on the screen.

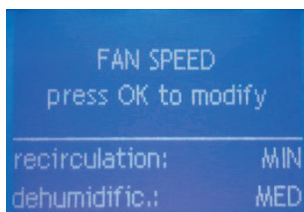

Some screens may not always be present.

Use this screen to change the fan speed in different operating modes:

1. In the recirculation mode, you can set the MINIMUM, MEDIUM or MAX speed;
2. In dehumidifying mode, you can set the MEDIUM or MAX speed.

Defaults: minimum speed for recirculation and medium speed for dehumidification.

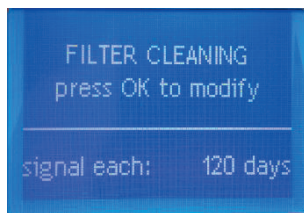

Use this screen to change the setting of the timer that notifies you when the filter needs to be cleaned.

If you set a period of 120 days, a message about the need to clean the filters will be displayed on the home page every 4 months.

Defaults: alarm is sent every 120 days.

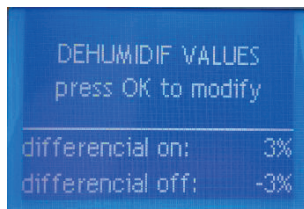

This screen is used to change the humidity differences that control the dehumidification command.

Defaults: humidity difference is 3% for on and -3% for off.

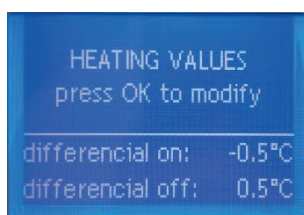

Use this screen to change the temperature differentials that control the heating command. This page only appears if you have purchased the optional hot water heat exchanger with valve or the heating electric resistor.

Defaults: temperature difference is -0.5°C for switching on and 0.5°C for switching off.

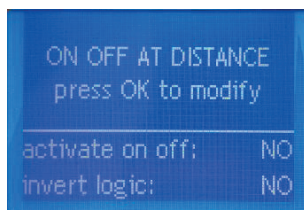

Use this screen to enable the remote device contact and, if necessary, to reverse the operating logic. This page is present only if communication via the Modbus interface is inactive.

Without changing the logic to the opposite:

- contact is open → device is off
- contact closed → device switched on

Defaults: remote control is enabled and logic reversal is inactive.

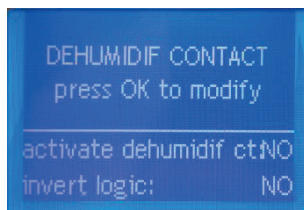

This screen is used to enable the dehumidification on/off contact and, if necessary, to reverse the operating logic. This page is present only if communication via the Modbus interface is inactive. Without changing the logic to the opposite:

- contact open → dehumidification command is inactive
- contact closed → dehumidification command active

Defaults: dehumidification contact and reverse logic are disabled.

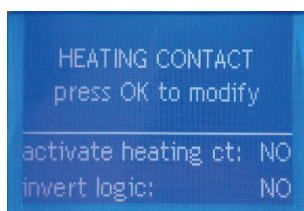

Use this screen to enable the heating on/off contact and, if necessary, to reverse the operating logic. This page only appears if the Modbus communication is not active and if an optional hot water exchanger with valve or heating electric resistor has been purchased. Without changing the logic to the opposite:

- contact open → heating command is inactive
- contact closed → heating command active

Defaults: dehumidification contact is enabled, and reversal of logic is disabled.

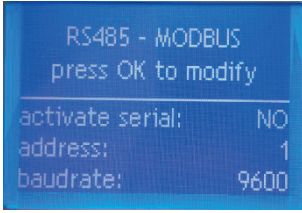

This screen is used to enable and change communication parameters via the Modbus interface. This page is only available if you have purchased the optional Modbus communication interface card.

Defaults: serial interface is disabled, the address is 1, and the baud rate is 9600 bps.

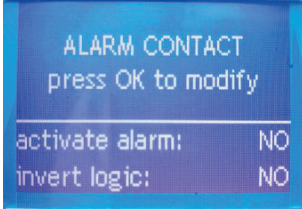

This screen is used to enable the alarm contact and, if necessary, to reverse the operating logic. This page is only present on MDDS/MDCS models without the optional hot gas defrosting system and on MDOS models regardless of the optional features installed. Without changing the logic to the opposite:

- contact is open → alarm is inactive
- contact closed → alarm active

Defaults: alarm contact is enabled and the reversal of logic is disabled.

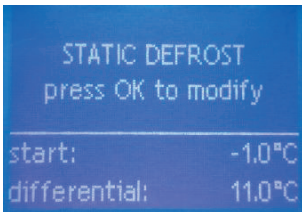

Use this screen to configure the settings for static frost defrosting.

This page is only available if you have not purchased the optional hot gas frost defrosting system.

Defaults: start at -1.0°C, and a temperature drop of 11.0°C.

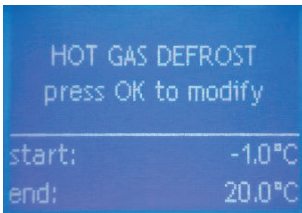

Use this screen to configure the settings for hot gas frost defrosting. This page is only available if you have purchased the optional hot gas frost defrosting system.

Defaults: start at -1.0°C, and a temperature difference of 20.0°C.

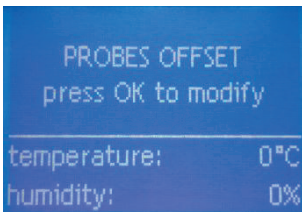

This screen is used to set up adjust offset ambient temperature and humidity sensors.

Defaults: 0°C and 0%.

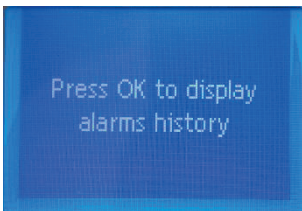

This screen provides access to the alarm log and allows you to display all stored alarms.

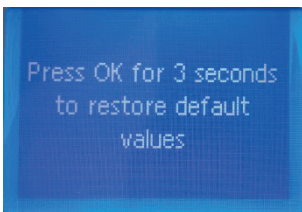

Restore all installer settings, user settings, and calibration settings. If the installer menu, the user menu, or the calibration menu. If any parameters have been changed by mistake, you can restore the original values of all parameters and return the device to the state in which it was purchased.

NOTE: Restoring all user settings, such as preferred temperature and humidity, deletes the season setpoint, all installer settings, and calibration settings, but does not delete the time range programming settings.

VIII. DIMENSIONAL DRAWINGS

8.1. MDDS

8.1.1. MDDS 40 – 50 – 60

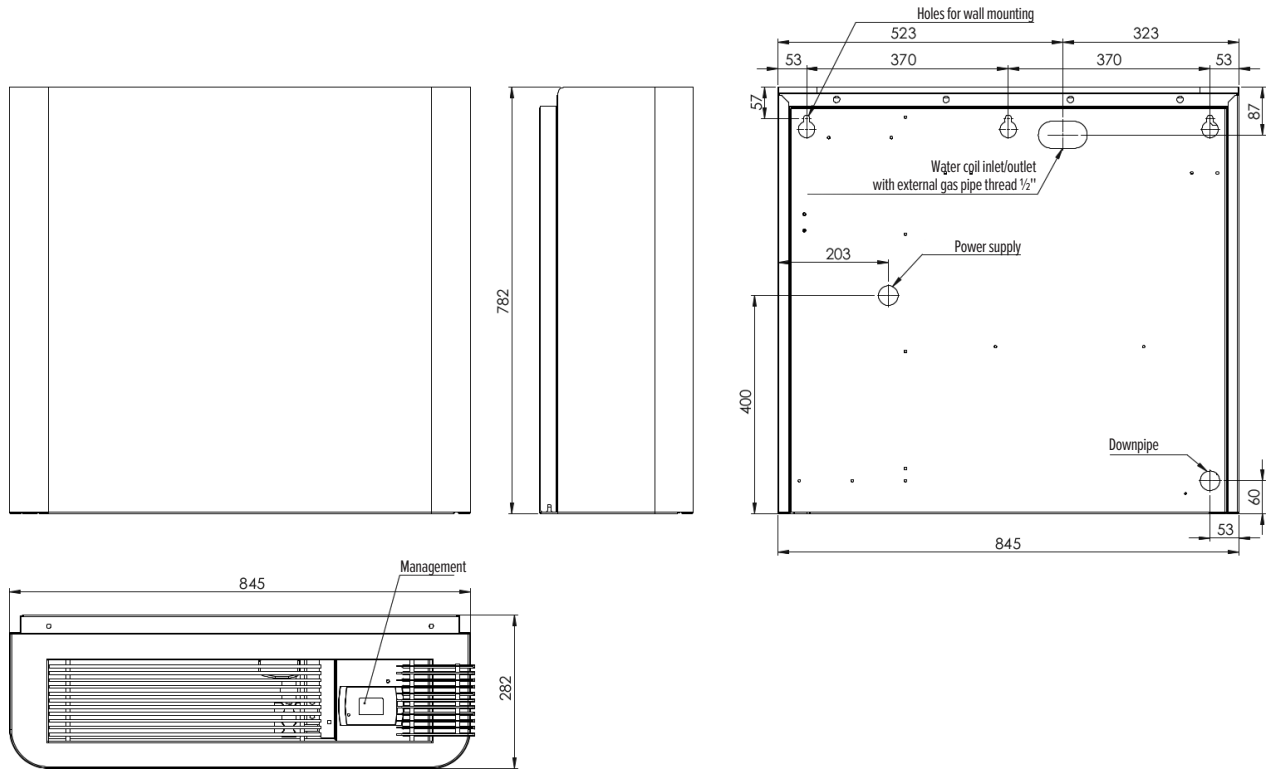

8.1.2. MDDS 70 – 90 – 100

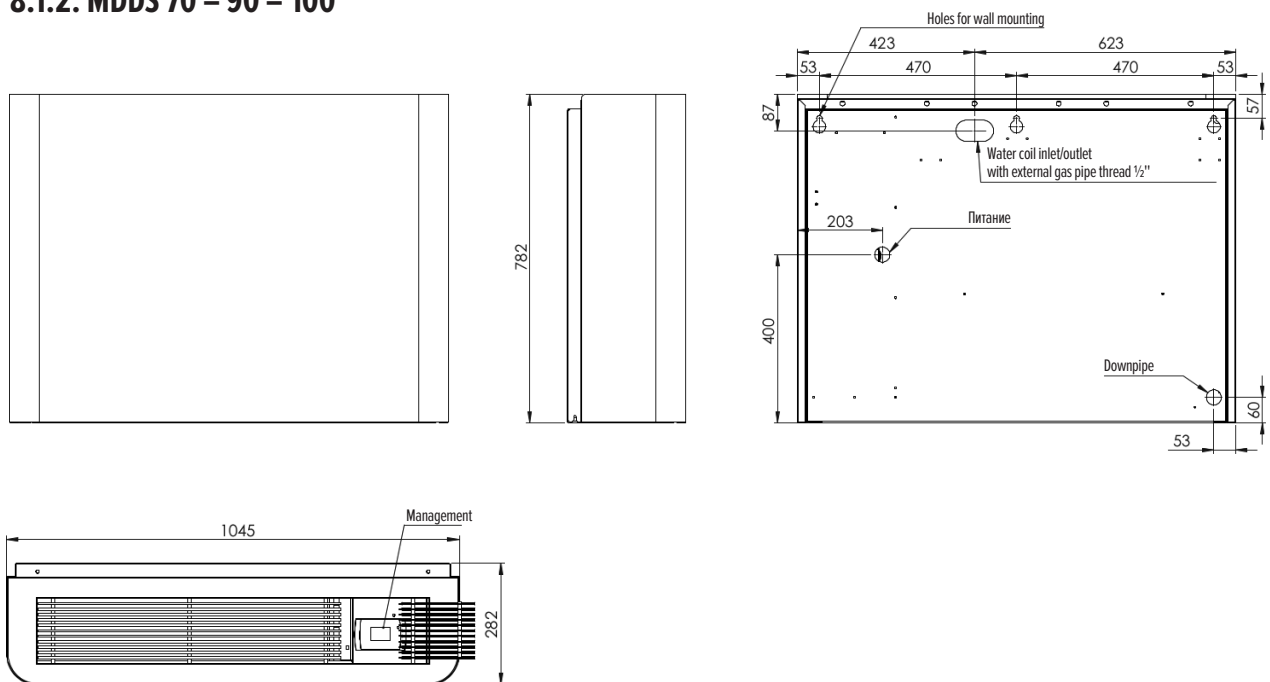

8.1.3. MDDS 160 – 190

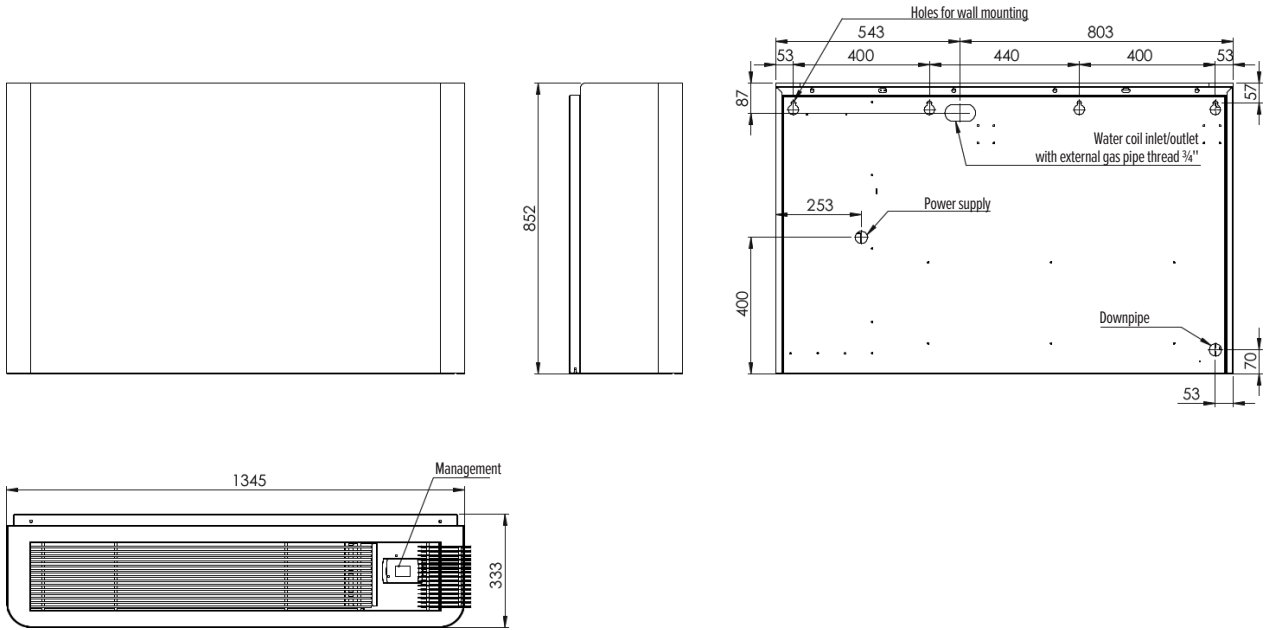

8.1.4. MDDS 210 – 230 – 300

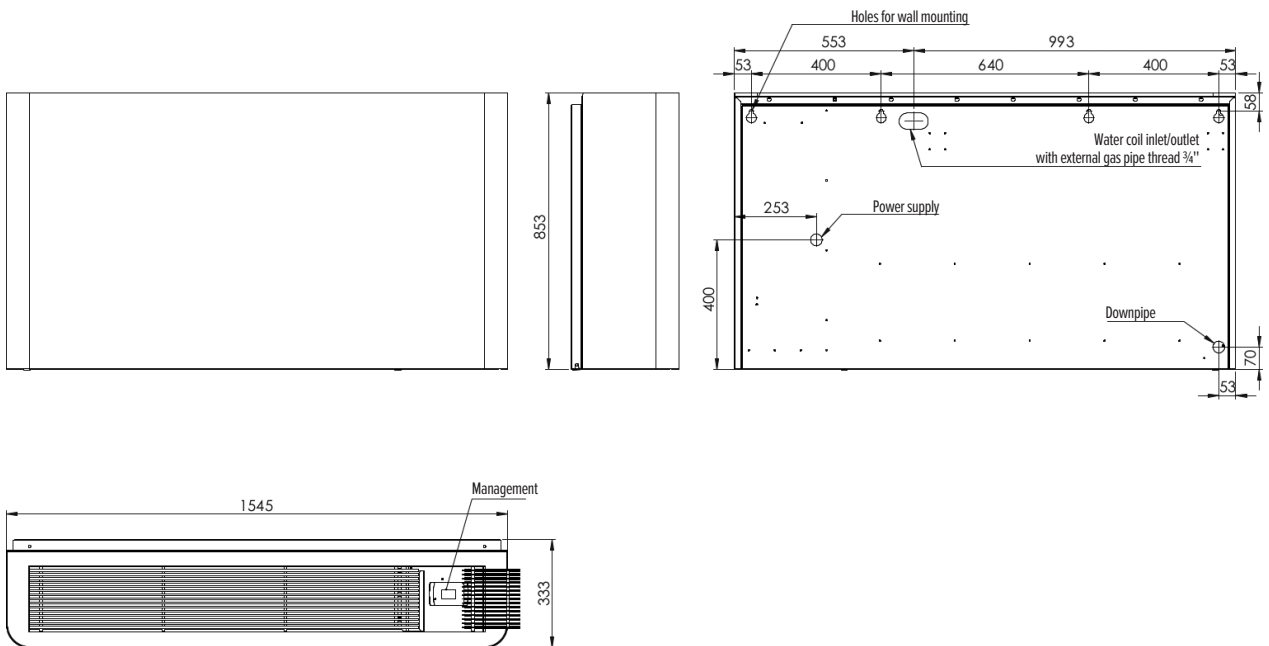

8.2. MDCS

8.2.1. MDCS 40 – 50 – 60

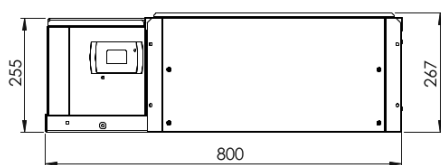
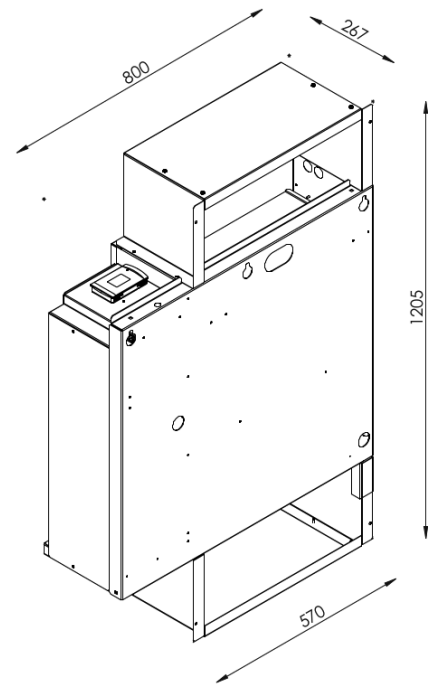
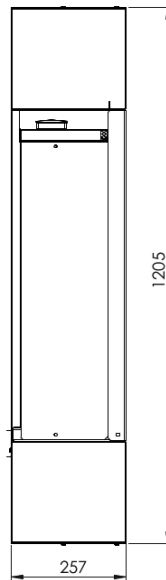
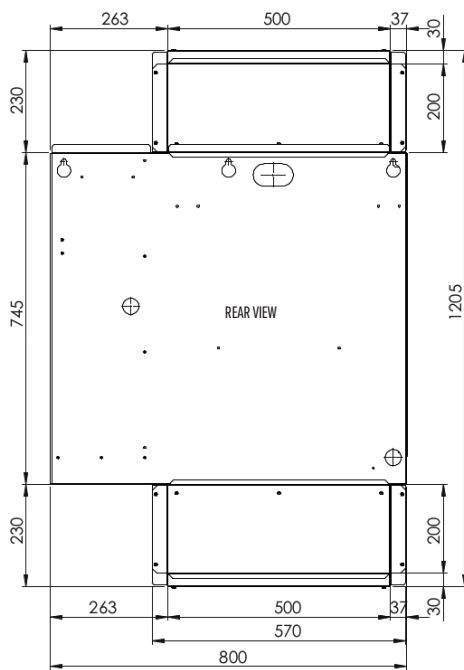
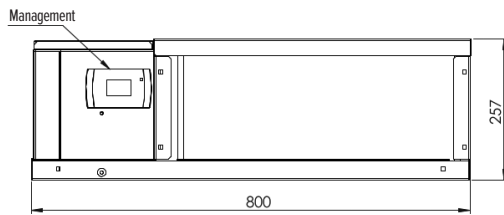
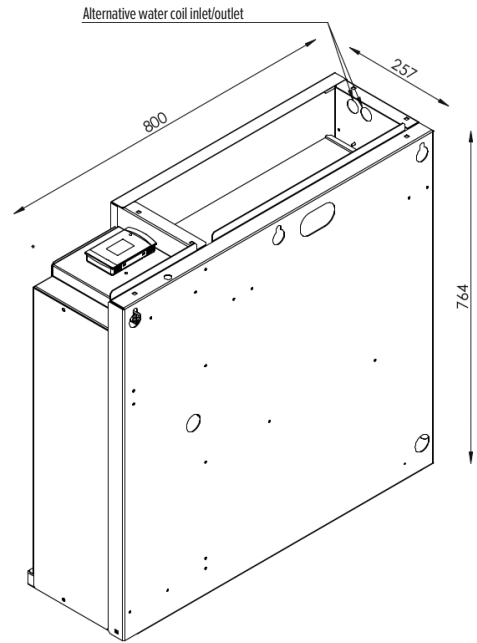
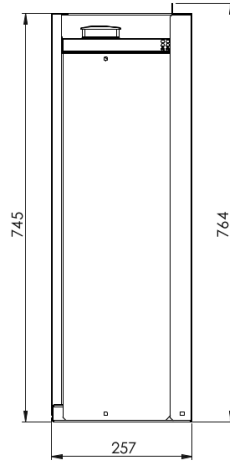
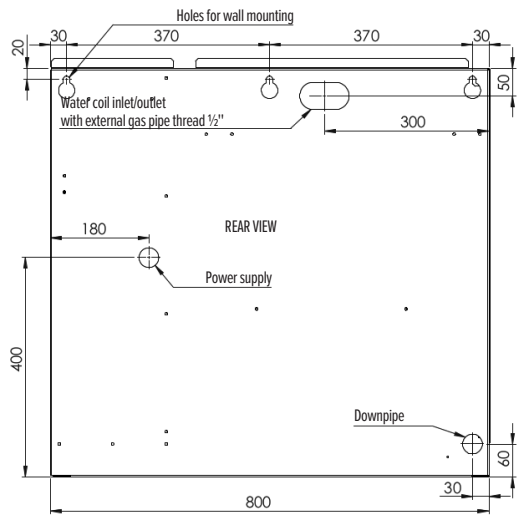

8.2.2. MDCS 70 – 90 – 100

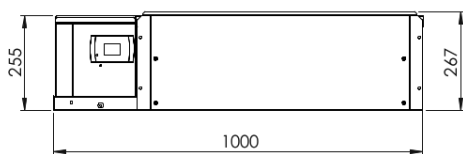
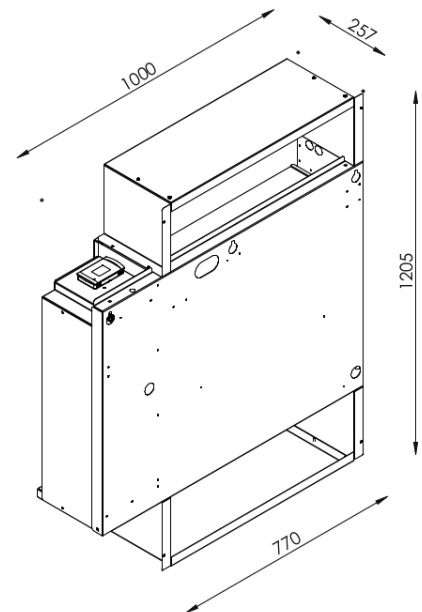
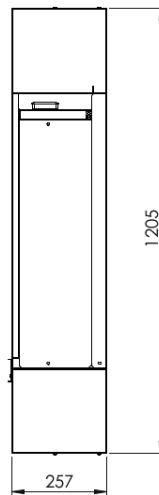
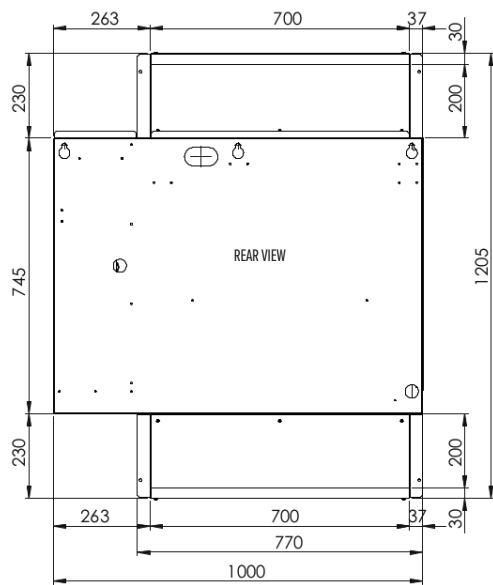
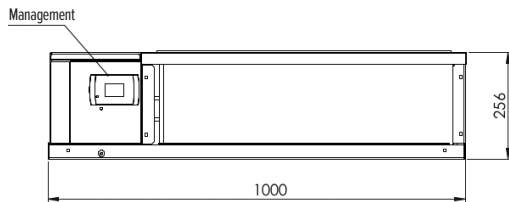
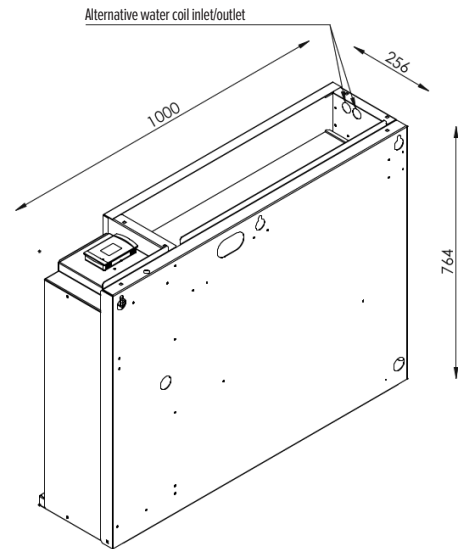
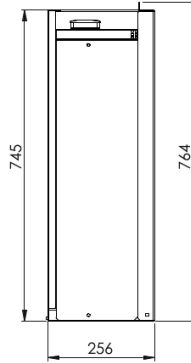
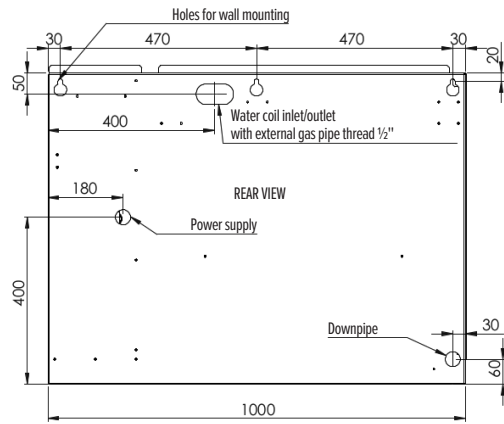

8.2.3. MDCS 160 – 190

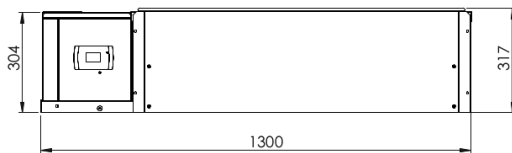
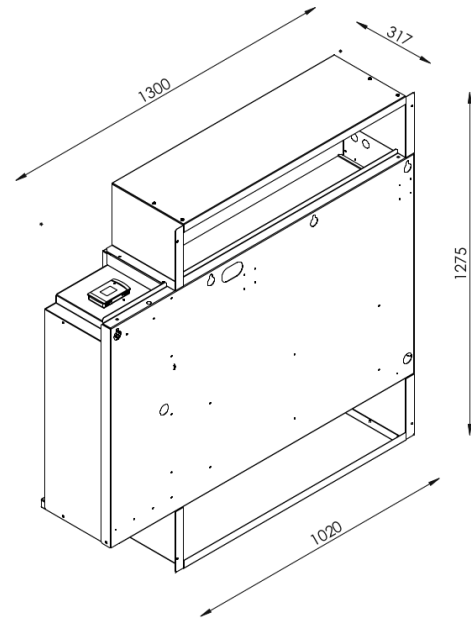
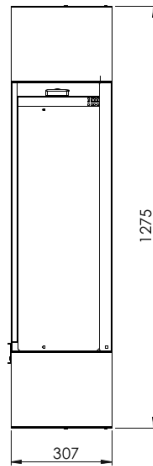
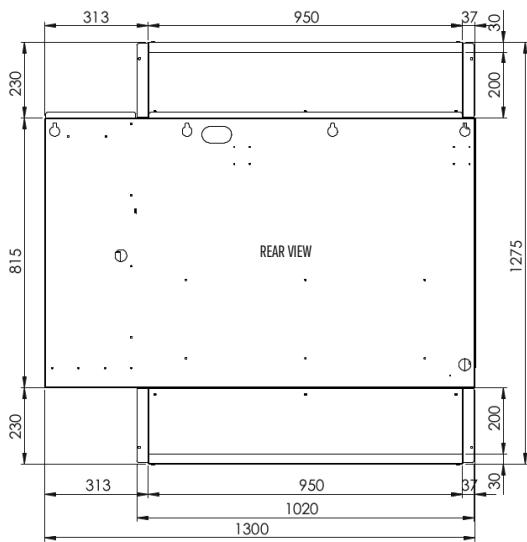
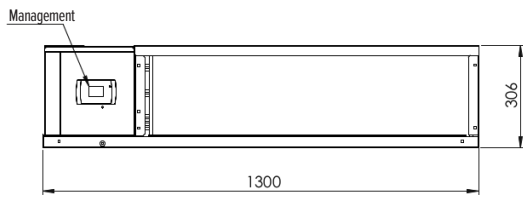
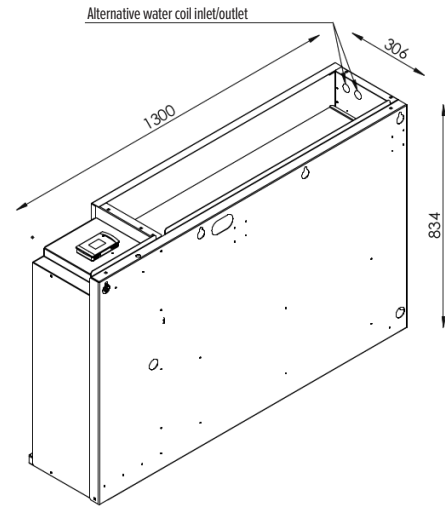
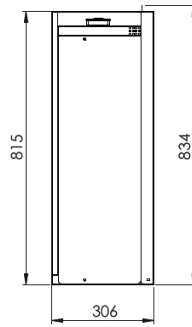
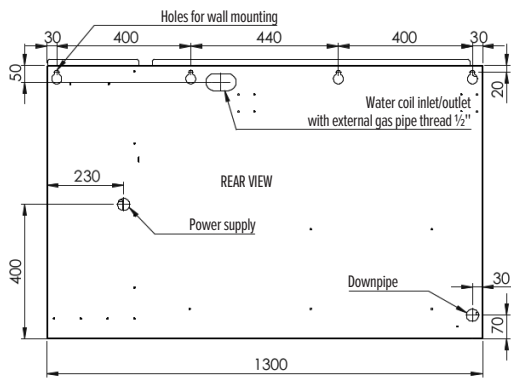

8.2.4. MDCS 210 – 230 – 300

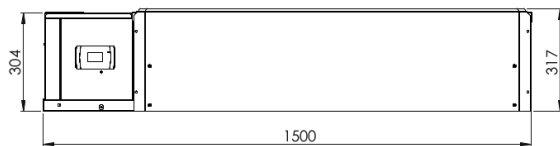
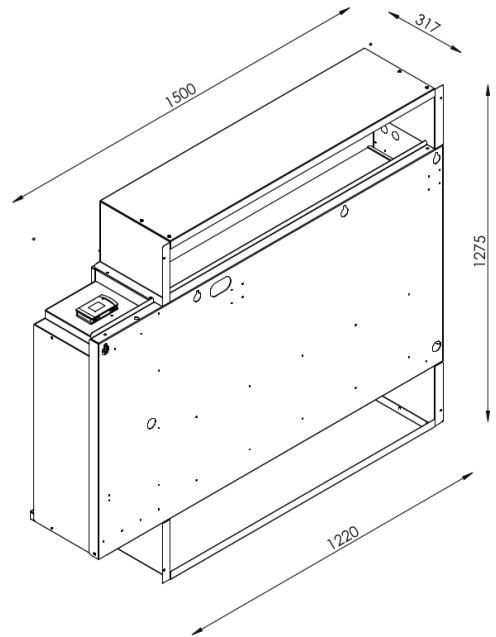
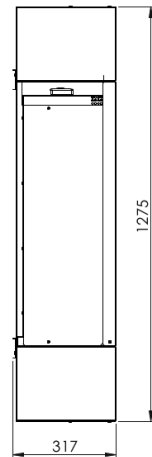
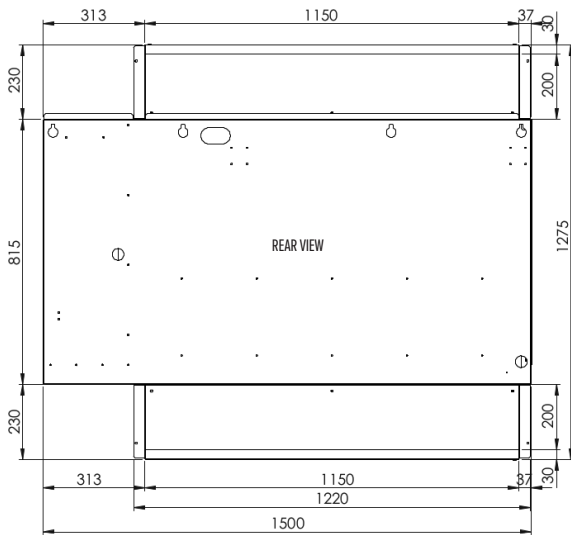
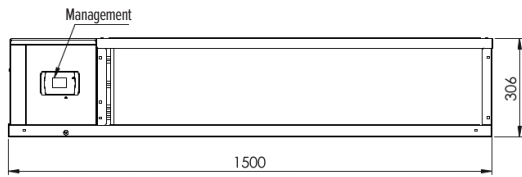
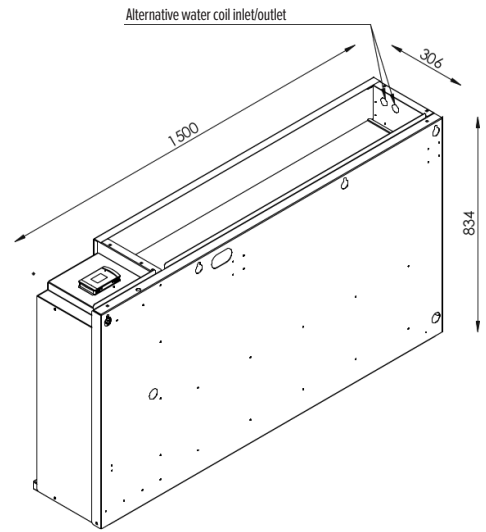
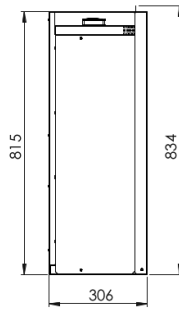
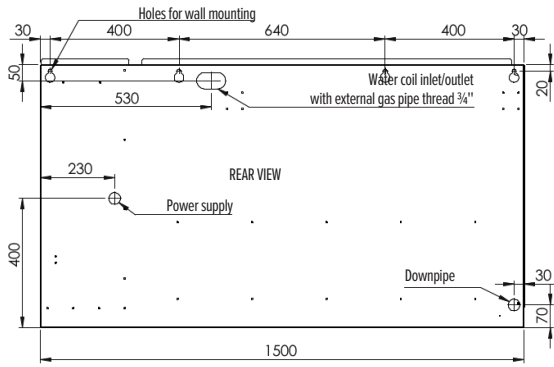

8.3. MDOS

8.3.1. MDOS 70 – 90 – 100

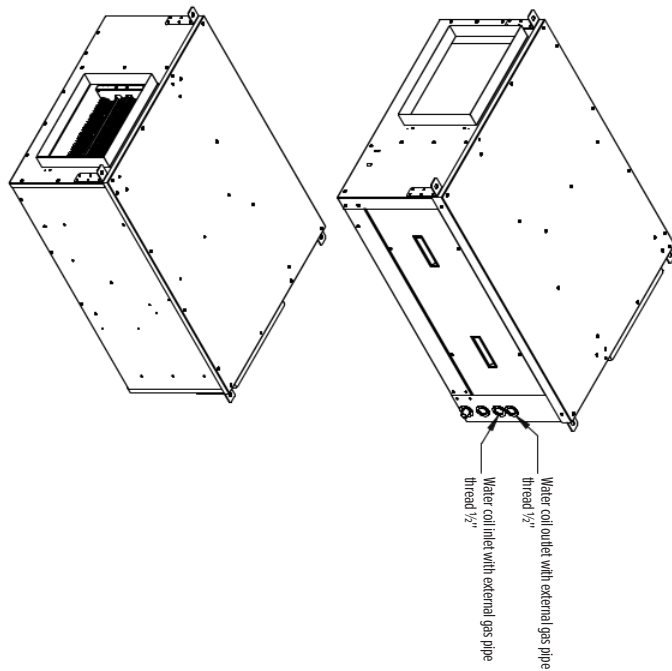
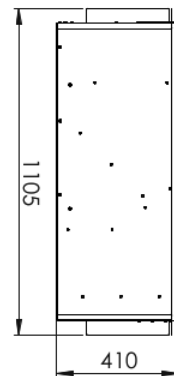
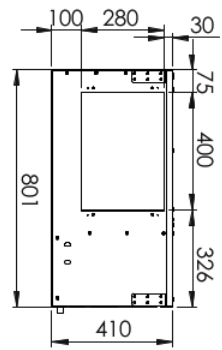
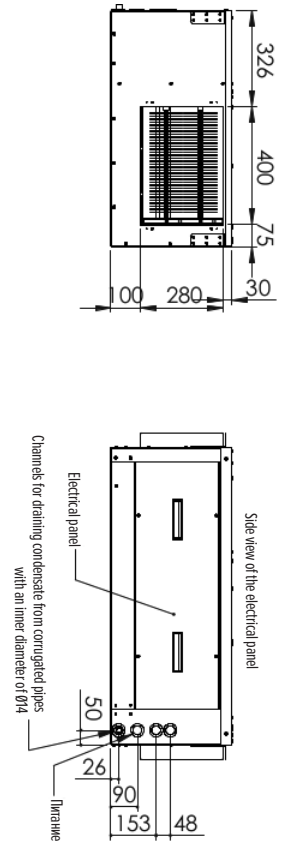
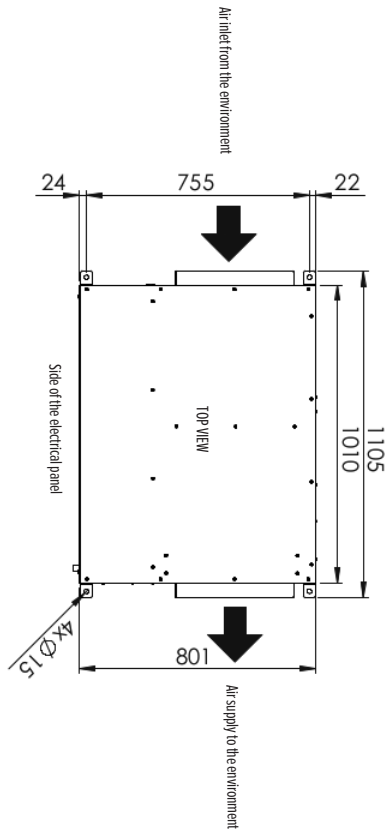
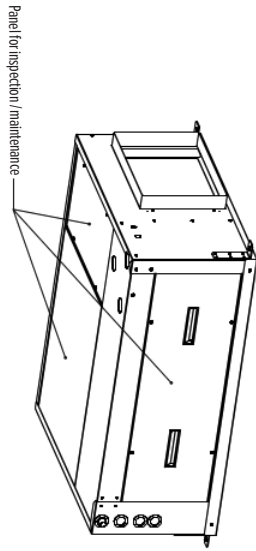

8.3.2. MD0S 160 – 190 – 210 – 230

